

LOW NO_x MODULATING GAS BURNERS

► RS/M BLU SERIES

► RS 25/M BLU	76/125 ÷ 370 kW
► RS 35/M BLU	100/200 ÷ 480 kW
► RS 45/M BLU	90/190 ÷ 550 kW
► RS 68/M BLU	150/350 ÷ 860 kW
► RS 120/M BLU	300/600 ÷ 1300 kW
► RS 160/M BLU	300/930 ÷ 1860 kW
► RS 200/M BLU	506/1383 ÷ 2400 kW



The RS/M BLU burners series covers a firing range from 125 to 2400 kW, and it has been designed for use in low or medium temperature hot water boilers, hot air or steam boilers, diathermic oil boilers.

Operation can be "two stage progressive" or, alternatively, "modulating" with the installation of a PID logic regulator and respective probes.

RS/M BLU burners series guarantees high efficiency levels in all the various applications, thus reducing fuel consumption and running costs.

The exclusive design ensures reduced dimensions, simple use and maintenance. A wide range of accessories guarantees elevated working flexibility.



TECHNICAL DATA

Model		▼RS25/M BLU	▼RS35/M BLU	▼RS45/M BLU	▼RS68/M BLU	▼RS120/M BLU	▼RS160/M BLU	▼RS200/M BLU		
Burner operation mode		Modulating (with regulator and probes accessories)								
Modulation ratio at max. output		4 ÷ 1			3 ÷ 1		4 ÷ 1			
Servo-motor	Type	SQN90			SQN31					
	Run time	24			42					
Heat output	kW	76/125÷370	100/200÷480	90/190÷550	150/350÷860	300/600÷1300	300/930÷1860	506/1383÷2400		
	Mcal/h	65/108÷318	86/172÷413	77/164÷473	129/301÷740	258/516÷1118	258/800÷1600	435/1189÷2064		
Working temperature		°C min./max. 0/40								
Net calorific value G20 gas		kWh/Nm ³ 10								
Density gas G20		kg/Nm ³ 0,71								
Output gas G20		Nm ³ /h 8/13÷37	10/20÷48	9/19÷55	15/35÷86	30/60÷130	30/93÷186	51/138÷240		
Net calorific value G25 gas		kWh/Nm ³ 8,6								
Density gas G25		kg/Nm ³ 0,78								
Output gas G25		Nm ³ /h 9/15÷43	12/23÷56	10,5/22÷64	17,5/41÷100	35/70÷151	35/108÷216	58/161÷279		
Net calorific value LPG gas		kWh/Nm ³ 25,8								
Density LPG gas		kg/Nm ³ 2,02								
Output LPG gas		Nm ³ /h 3/5÷14	4/8÷19	--						
Fan		Type (02)		(01)			(02)			
Air temperature		Max. °C 60								
Electrical supply		Ph/Hz/V (04)	(04)	(06)	(03)	(05)	(05)	(05)	(07)	(08)
Auxiliary electrical supply		Ph/Hz/V (04)	(04)	(04)	(03)	(03)	(03)	(03)	(03)	
Control box		Type RMG/M (intermittent operation) - LGK16 (continuous operation)								
Total electrical power		kW 0,6	0,7	0,75	0,6	2,0	2,8	5,3	8,2	
Auxiliary electrical power		kW 0,3	0,28	0,3	0,18	0,3	0,3	0,3	0,3	
Protection level		IP 40			44					
Motor electrical power		kW 0,3	0,42	0,45	0,42	1,5	2,2	4,5	6,6	
Rated motor current		A 3,2	3,5	2 - 1,4	2,9	5,9 - 3,4	8,8 - 5,1	15,8 - 9,1	14	24
Motor start current		A 15	17	14 - 10	9,2	32,8 - 19	55,4 - 32	126 - 72,8	116	204
Motor protection level		IP 54								
Ignition transformer		V1 - V2	230V - 1x15 kV			230V - 1x8 kV				
		I1 - I2	1A - 25 mA		45vA - 25 mA	1A - 20 mA				
Operation		Intermittent (at least one stop every 24 h) - Continuous (at least one stop every 72 h)								
Sound pressure		dBa 70	72	70	77	78,5	80,5	83		
Sound output		W --								
CO Emission		mg/kWh < 20								
NOx Emission		mg/kWh < 80								
Directive		90/396 - 89/336 (2004/108) - 73/23 - 92/42 EC					90/396 - 89/336 (2004/108) - 73/23 EC			
Conforming to		EN 676								
Certification		CE-0085BR0379			CE 0085 BM 0104 BUWAL n°101011	CE 0085 BM 0452			in progress	

- (01) Centrifugal with reverse curve blades
- (02) Centrifugal with forward curve blades
- (03) 1/50/230~(±10%)
- (04) 1/50-60/220-230~(±10%)
- (05) 3/50/230-400~(±10%)
- (06) 3/50-60/220-400~(±10%)
- (07) 3/50/400~(±10%)
- (08) 3/50/230~(±10%)

Reference conditions:

Temperature: 20°C
 Pressure: 1013.5 mbar
 Altitude: 100 m a.s.l.
 Noise measured at a distance of 1 meter.

Since the Company is constantly engaged in the production improvement, the aesthetic and dimensional features, the technical data, the equipment and the accessories can be changed.

This document contains confidential and proprietary information of RIELLO S.p.A. Unless authorised, this information shall not be divulged, nor duplicated in whole or in part.

FIRING RATES

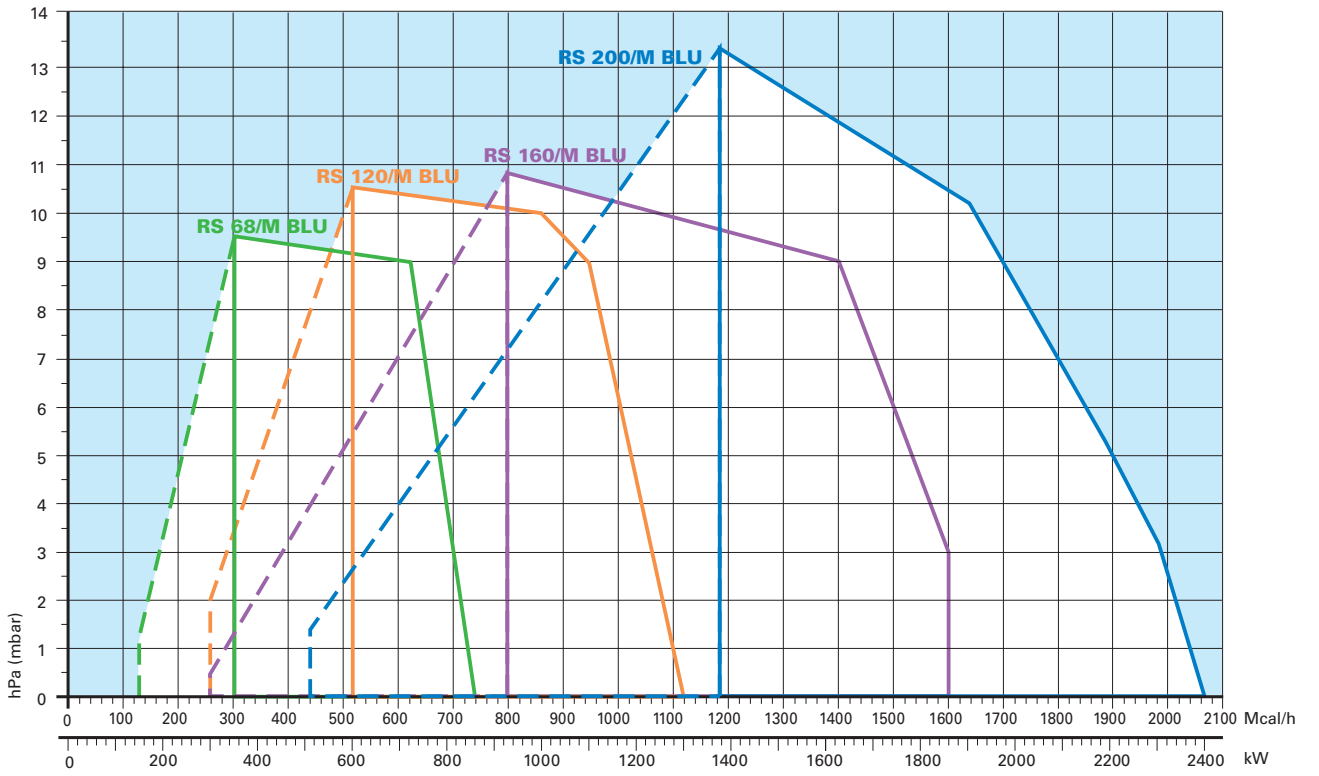
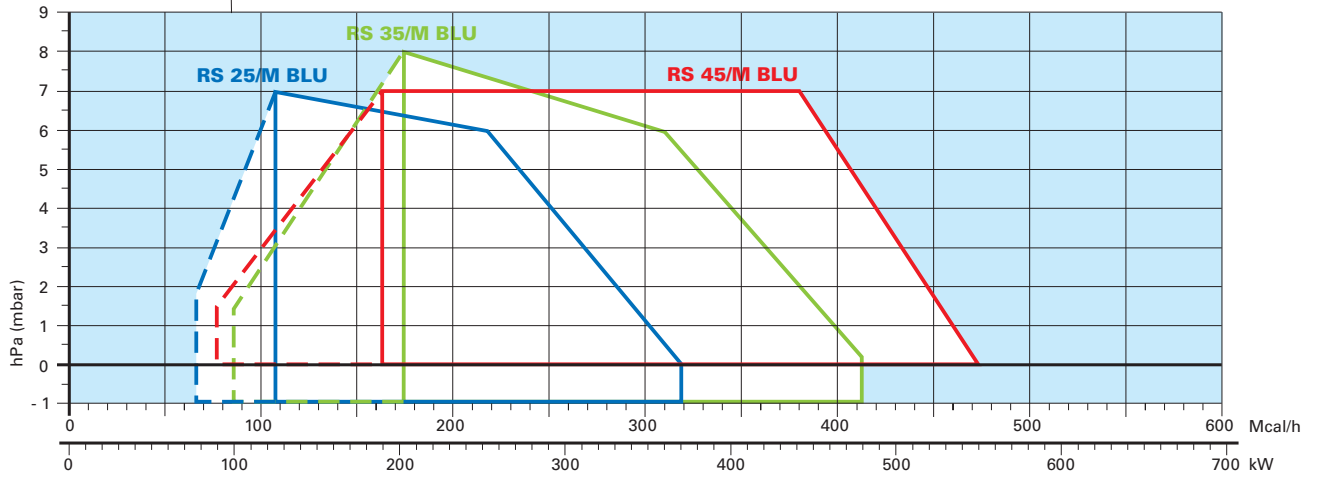

 Useful working field for choosing the burner

 Modulation range

Test conditions conforming to EN 676:

Temperature: 20°C
 Pressure: 1000 mbar
 Altitude: 100 m a.s.l.





FUEL SUPPLY

GAS TRAIN

The burners are fitted with a butterfly valve to regulate the fuel, controlled by a variable profile cam servomotor. Fuel can be supplied either from the right or left hand sides.

A maximum gas pressure switch stops the burner in case of excess pressure in the fuel line (as accessory on RS 25-35/M BLU).

The gas train can be selected to best fit system requirements depending on the fuel output and pressure in the supply line.

The gas train can be "Multibloc" type (containing the main components in a single unit) or "Composed" type (assembly of the single components).



Example of the variable profile cam on RS 25-35/M BLU burners.

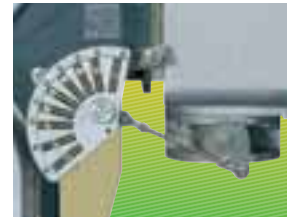

Example of the variable profile cam on RS 160/M BLU burners.

MULTIBLOC MBD gas train without seal control

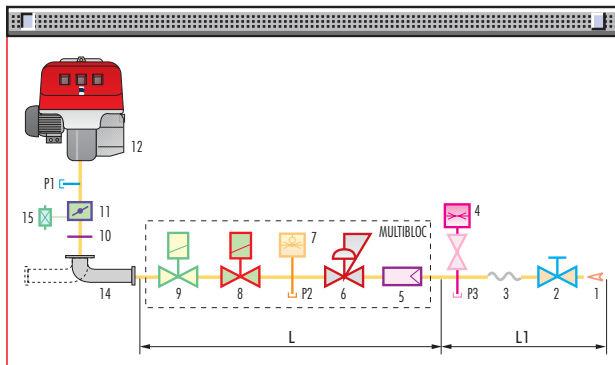

MULTIBLOC MBD gas train with seal control

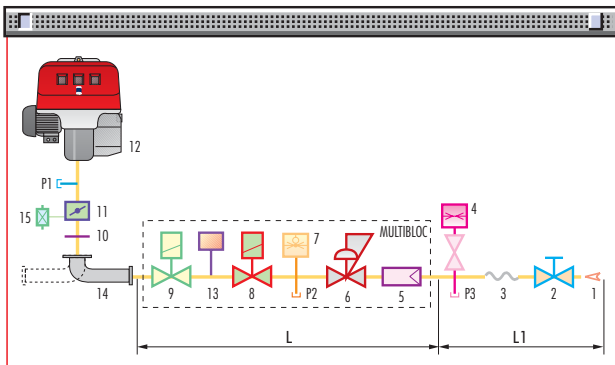

1	Gas input pipework
2	Manual valve
3	Anti-vibration joint
4	Pressure gauge with pushbutton cock
5	Filter
6	Pressure regulator (vertical)
7	Minimum gas pressure switch
8	VS safety solenoid (vertical)
9	VR regulation solenoid (vertical) Two settings: - firing output (rapid opening) - maximum output (slow opening)
10	Gasket and flange supplied with the burner
11	Gas adjustment butterfly valve
12	Burner
13	Seal control mechanism for valves 8-9. According to standard EN 676, the seal control is compulsory for burners with maximum output above 1200 kW
14	Gas train-burner adapter.
15	Maximum gas pressure switch
P1	Combustion head pressure
P2	Pressure downstream from the regulator
P3	Pressure upstream from the filter
L	Gas train supplied separately, with the code given in the table
L1	Installer's responsibility

MULTIBLOC MBC gas train

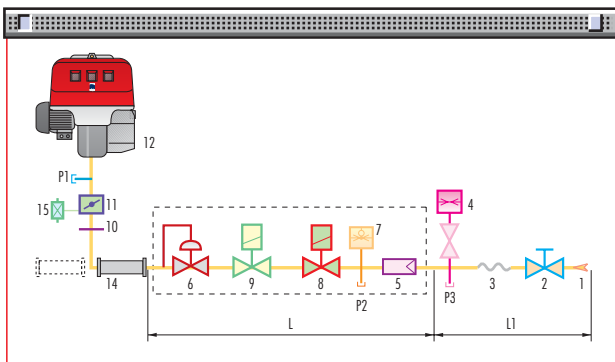

COMPOSED gas train

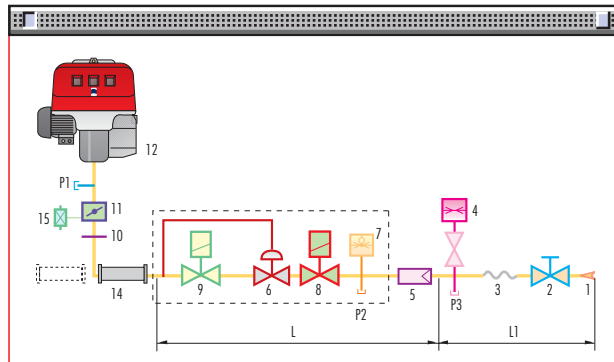

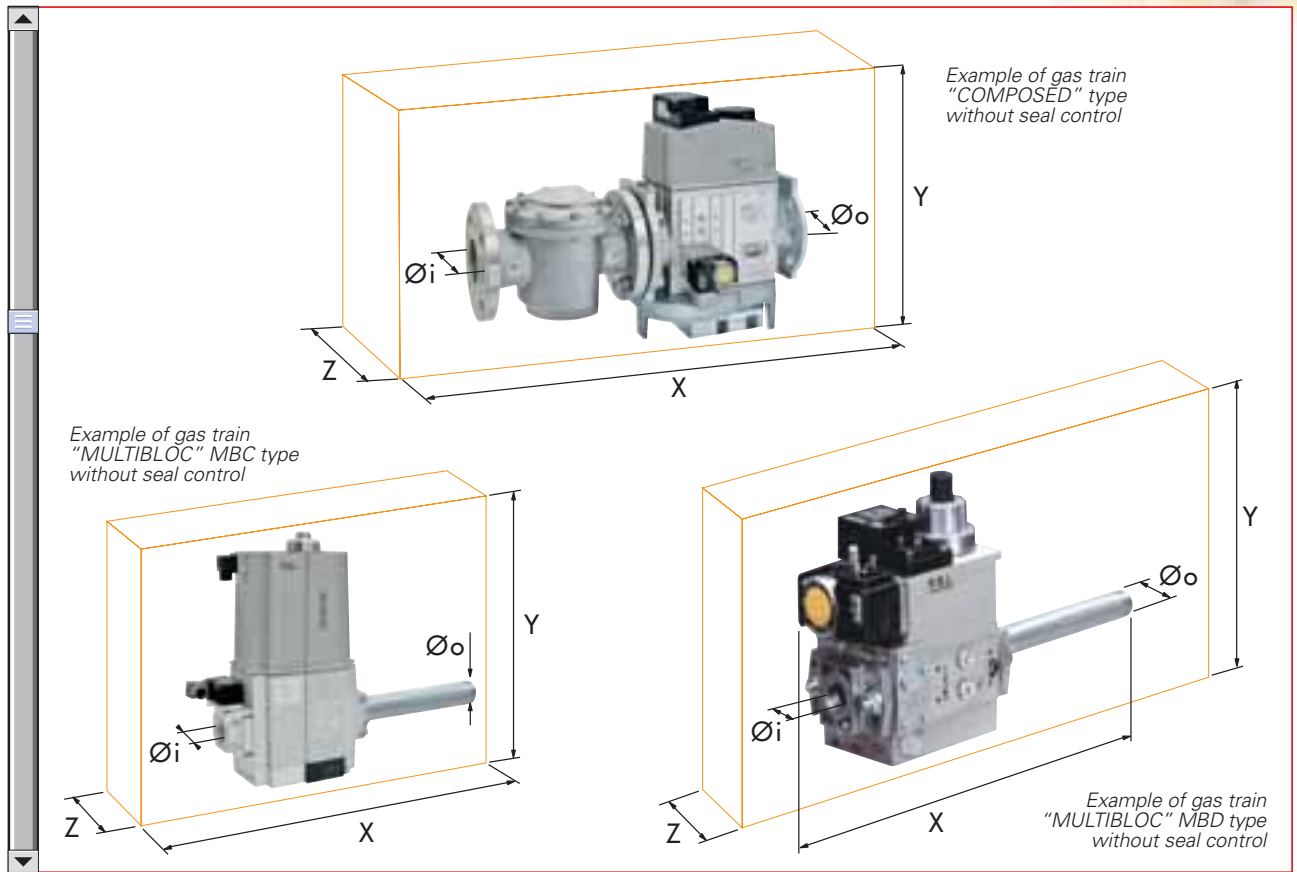

Gas trains are approved by standard EN 676 together with the burner. The overall dimensions of the gas train depends on how they are constructed. The following table shows the maximum dimensions of the gas trains that can be fitted to RS/M BLU burners, intake and outlet diameters and seal control if fitted. Please note that the seal control can be installed as an accessory, if not already installed on the gas train. The maximum gas pressure of gas train "Multibloc" type is 360 mbar, and the one of gas train "Composed" type is 500 mbar. The range of pressure in the MULTIBLOC with flange can be modified choosing the stabiliser spring (see gas train accessory).

	Name	Code	Ø i	Ø o	X mm	Y mm	Z mm	Output pressure range (mbar)	Seal Control
MULTIBLOC GAS TRAINS	MBD 405	3970500 (1)	3/4"	3/4"	371	186	120	4 - 20	Accessory
	MBD 407	3970553 (1) 3970229 (2)	3/4"	3/4"	371	196	120	4 - 20	Accessory
	MBD 410	3970554 (1) 3970230 (2)	1"	3/4"	405	217	145	4 - 20	Accessory
	MBD 412	3970144 (1) 3970231 (2)	1"1/4	1"1/4	433	217	145	4 - 20	Accessory
	MBD 412 CT	3970197 (1)	1"1/4	1"1/4	433	217	262	4 - 20	Incorporated
	MBD 415	3970180 (1) 3970232 (2)	1"1/2	1"1/2	523	250	100	4 - 33	Accessory
	MBD 415 CT	3970198 (1)	1"1/2	1"1/2	523	250	227	4 - 33	Incorporated
	MBD 420	3970181 (1) 3970233 (2)	2"	2"	523	300	100	4 - 33	Accessory
	MBD 420 CT	3970182 (1) 3970234 (2)	2"	2"	523	300	227	4 - 33	Incorporated
	MBC 1200 SE 50	3970221 (2)	2"	2"	573	425	161	4 - 60	Accessory
MBC 1200 SE 50 CT	3970225 (2)	2"	2"	573	425	288	4 - 60	Incorporated	
COMPOSED GAS TRAINS	MBC 1900 SE 65 FC	3970222 (2)	DN 65	DN 65	583	430	237	20 - 40	Accessory
	MBC 1900 SE 65 FC CT	3970226 (2)	DN 65	DN 65	583	430	364	20 - 40	Incorporated
	MBC 3100 SE 80 FC	3970223 (2)	DN 80	DN 80	633	500	240	20 - 40	Accessory
	MBC 3100 SE 80 FC CT	3970227 (2)	DN 80	DN 80	633	500	367	20 - 40	Incorporated

(1) Gas Train with 6-pin plug to install for connection to the burner.
 (2) Gas Train with 6-pin plug installed for connection to the burner.



► PRESSURE DROP DIAGRAM

The diagrams indicate the minimum pressure drop of the burners with the various gas trains that can be matched with them; at the value of these pressure drop add the combustion chamber pressure. The value thus calculated represents the minimum required input pressure to the gas train.

NATURAL GAS

RS 25/M BLU

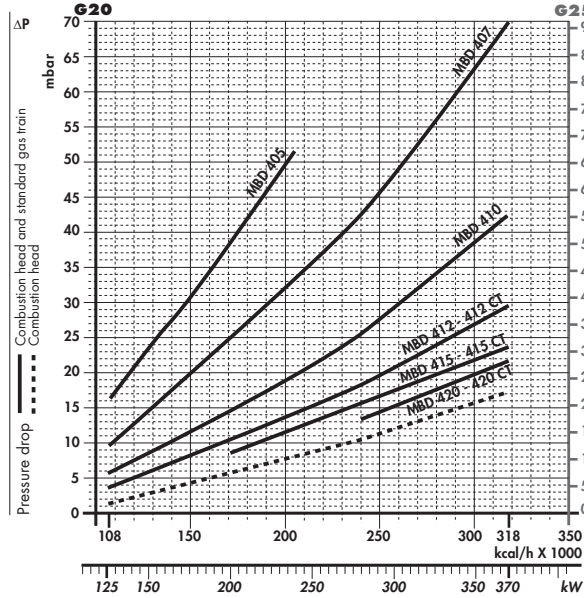

Gas train	Code	Adapter	Seal Control
MBD 405	3970500 (1)	3000824	Accessory
MBD 407	3970553 (1) 3970229 (2)	3000824	Accessory
MBD 410	3970554 (1) 3970230 (2)	3000824	Accessory
MBD 412	3970144 (1) 3970231 (2)	-	Accessory
MBD 412 CT	3970197 (1)	-	Incorporated

LPG

RS 25/M BLU

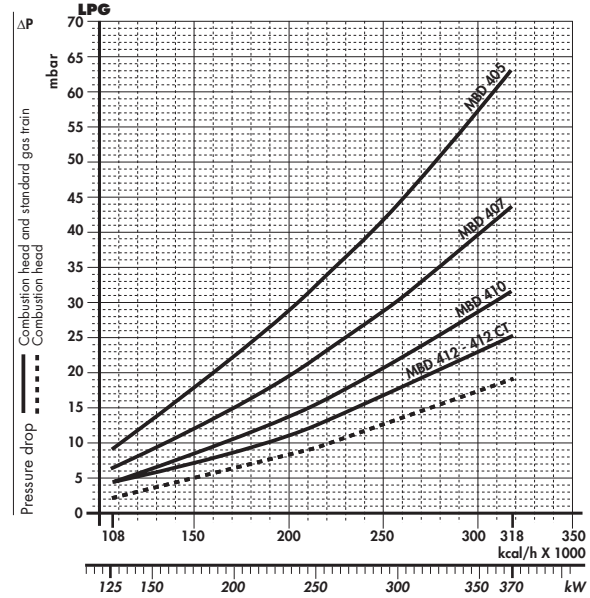

Gas train	Code	Adapter	Seal Control
MBD 415	3970180 (1) 3970232 (2)	-	Accessory
MBD 415 CT	3970198 (1)	-	Incorporated
MBD 420	3970181 (1) 3970233 (2)	3000822	Accessory
MBD 420 CT	3970182 (1) 3970234 (2)	3000822	Incorporated

(1) Gas Train with 6-pin plug to install for connection to the burner.
(2) Gas Train with 6-pin plug installed for connection to the burner.

RS 35/M BLU

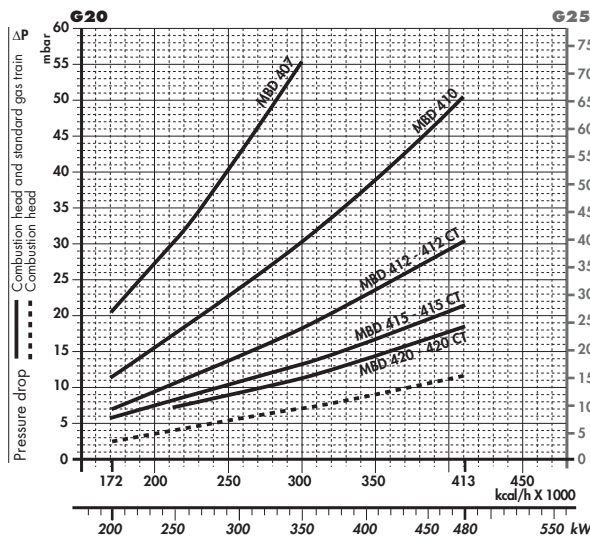

Gas train	Code	Adapter	Seal Control
MBD 405	3970500 (1)	3000824	Accessory
MBD 407	3970553 (1) 3970229 (2)	3000824	Accessory
MBD 410	3970554 (1) 3970230 (2)	3000824	Accessory
MBD 412	3970144 (1) 3970231 (2)	-	Accessory
MBD 412 CT	3970197 (1)	-	Incorporated

RS 35/M BLU

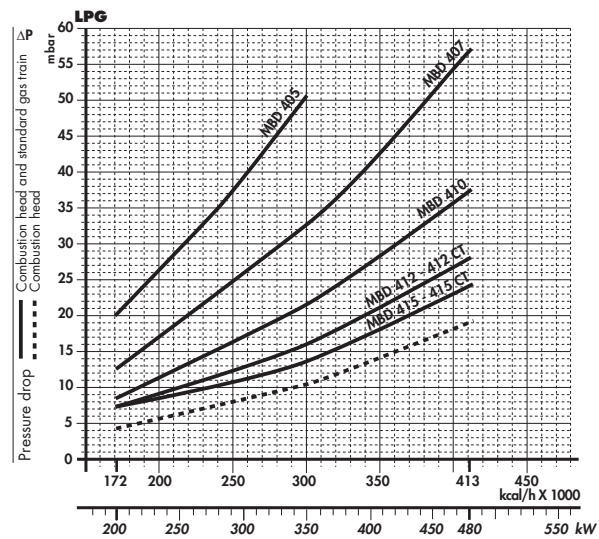

Gas train	Code	Adapter	Seal Control
MBD 415	3970180 (1) 3970232 (2)	-	Accessory
MBD 415 CT	3970198 (1)	-	Incorporated
MBD 420	3970181 (1) 3970233 (2)	3000822	Accessory
MBD 420 CT	3970182 (1) 3970234 (2)	3000822	Incorporated

(1) Gas Train with 6-pin plug to install for connection to the burner.
(2) Gas Train with 6-pin plug installed for connection to the burner.



NATURAL GAS

RS 45/M BLU

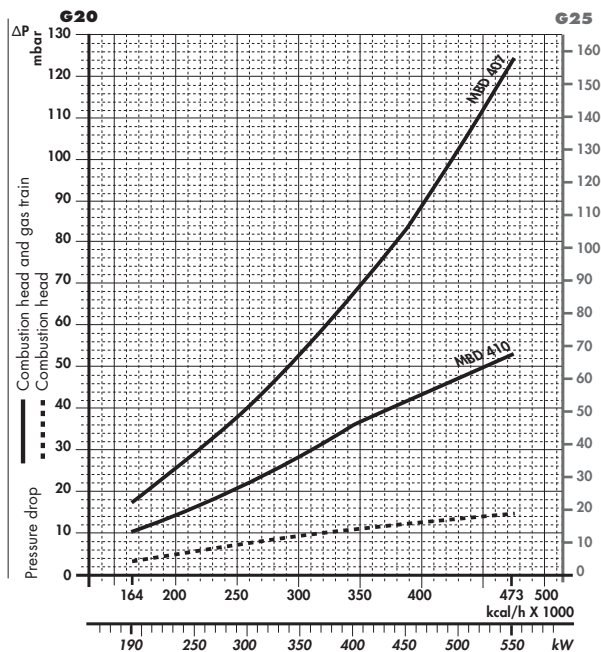

Gas train	Code	Adapter	Seal Control
MBD 407	3970553 (1)	3000824	Accessory
	3970229 (2)	3000824	Accessory
MBD 410	3970554 (1)	3000824	Accessory
	3970230 (2)	3000824	Accessory

(1) Gas Train with 6-pin plug to install for connection to the burner.
 (2) Gas Train with 6-pin plug installed for connection to the burner.

RS 45/M BLU

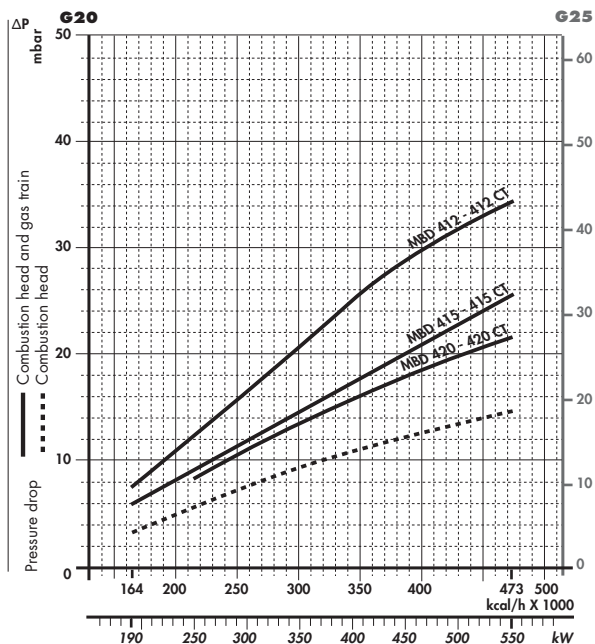

Gas train	Code	Adapter	Seal Control
MBD 412	3970144 (1)	-	Accessory
	3970231 (2)	-	Accessory
MBD 412 CT	3970197 (1)	-	Incorporated
MBD 415	3970180 (1)	-	Accessory
	3970232 (2)	-	Accessory
MBD 415 CT	3970198 (1)	-	Incorporated
MBD 420	3970181 (1)	3000822	Accessory
	3970233 (2)	3000822	Accessory
MBD 420 CT	3970182 (1)	3000822	Incorporated
	3970234 (2)	3000822	Incorporated

(1) Gas Train with 6-pin plug to install for connection to the burner.
 (2) Gas Train with 6-pin plug installed for connection to the burner.



NATURAL GAS

RS 68/M BLU

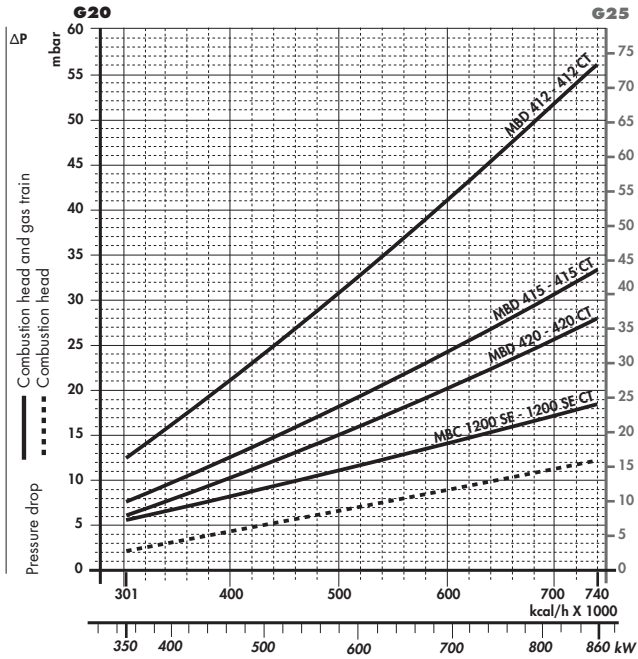

Gas train	Code	Adapter	Seal Control
MBD 412	3970144	3000843	Accessory
MBD 412 CT	3970197	3000843	Incorporated
MBD 415	3970180	3000843	Accessory
MBD 415 CT	3970198	3000843	Incorporated
MBD 420	3970181	-	Accessory
MBD 420 CT	3970182	-	Incorporated
MBC 1200 SE	3970221	-	Accessory
MBC 1200 SE CT	3970225	-	Incorporated

RS 120/M BLU

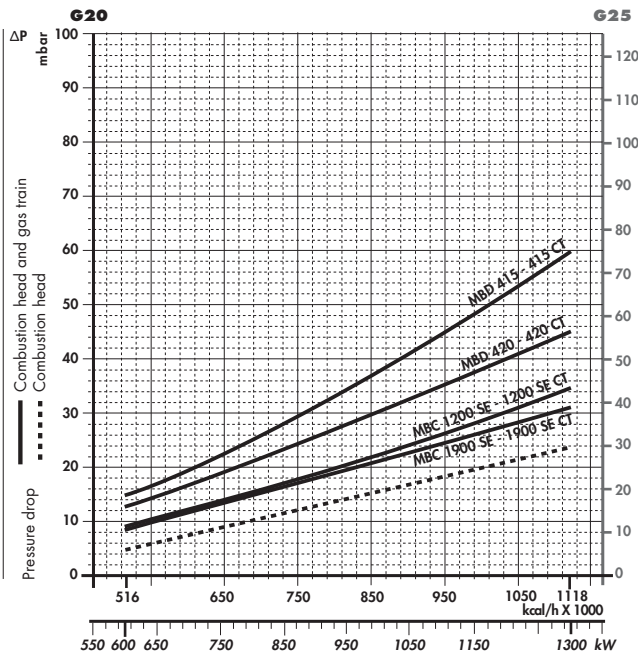

Gas train	Code	Adapter	Seal Control
MBD 415	3970180	3000843	Accessory
MBD 415 CT	3970198	3000843	Incorporated
MBD 420	3970181	-	Accessory
MBD 420 CT	3970182	-	Incorporated
MBC 1200 SE	3970221	-	Accessory
MBC 1200 SE CT	3970225	-	Incorporated
MBC 1900 SE	3970222	3000825	Accessory
MBC 1900 SE CT	3970226	3000825	Incorporated



NATURAL GAS

RS 160/M BLU

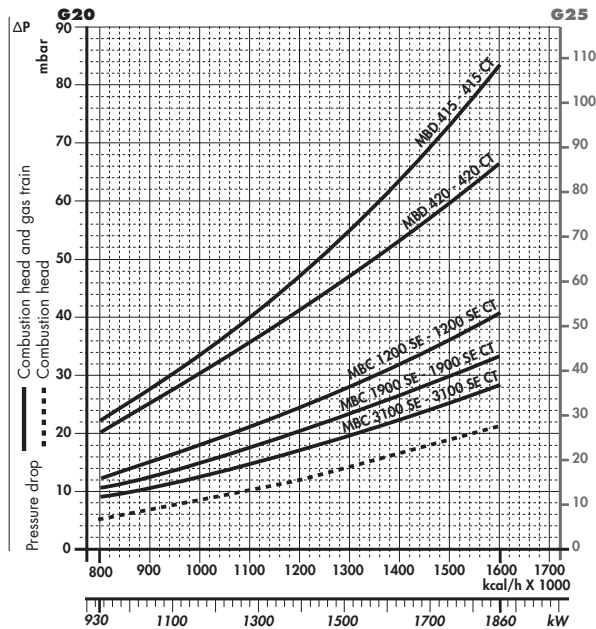

Gas train	Code	Adapter	Seal Control
Mbd 415	3970180	3000843	Accessory
Mbd 415 CT	3970198	3000843	Incorporated
Mbd 420	3970181	-	Accessory
Mbd 420 CT	3970182	-	Incorporated
Mbc 1200 SE	3970221	-	Accessory
Mbc 1200 SE CT	3970225	-	Incorporated
Mbc 1900 SE	3970222	3000825	Accessory
Mbc 1900 SE CT	3970226	3000825	Incorporated
Mbc 3100 SE	3970223	3000826	Accessory
Mbc 3100 SE CT	3970227	3000826	Incorporated

RS 200/M BLU

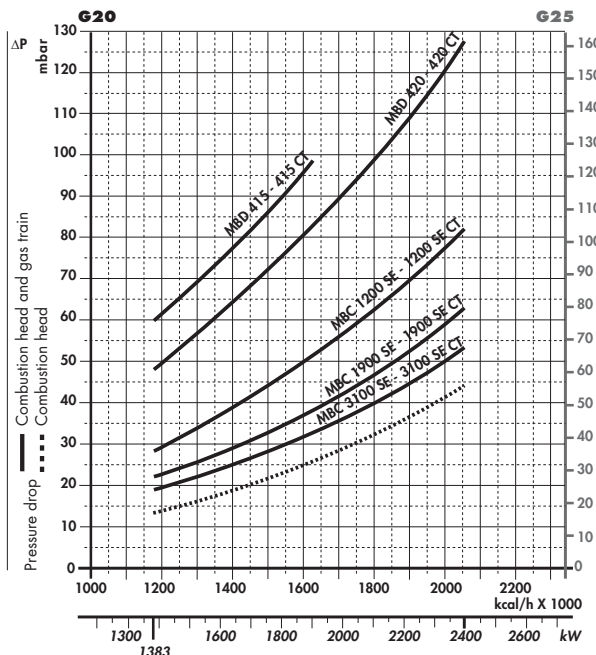

Gas train	Code	Adapter	Seal Control
Mbd 415	3970180	3000843	Accessory
Mbd 415 CT	3970198	3000843	Incorporated
Mbd 420	3970181	-	Accessory
Mbd 420 CT	3970182	-	Incorporated
Mbc 1200 SE	3970221	-	Accessory
Mbc 1200 SE CT	3970225	-	Incorporated
Mbc 1900 SE	3970222	3000825	Accessory
Mbc 1900 SE CT	3970226	3000825	Incorporated
Mbc 3100 SE	3970223	3000826	Accessory
Mbc 3100 SE CT	3970227	3000826	Incorporated

note Please contact the Riello Burner Technical Office for different pressure levels from those above indicated and refer to the technical manual for the correct choice of the spring.

In LPG plants, Multibloc gas trains do not operate below 0°C. They are only suitable for gaseous LPG (liquid hydrocarbons destroy the seal materials).

MBC 1200 gas train: the minimum operating pressure (*) is higher or equal to 10 mbar. The gas train has to be installed next to the burner (if needed, only with the adapters listed in the catalogue) and it has to operate in its own working field.

MBC 1900-3100 gas train: the minimum operating pressure (*) is higher or equal to 15 mbar. The gas train has to be installed next to the burner (if needed, with the adapters listed in the catalogue) and it has to operate in its own working field.

(*) it is the upstream gas train pressure in full load operation conditions.





SELECTING THE FUEL SUPPLY LINES

The following diagram enables pressure drop in a pre-existing gas line to be calculated and to select the correct gas train.

The diagram can also be used to select a new gas line when fuel output and pipe length are known. The pipe diameter is selected on the basis of the desired pressure drop. The diagram uses methane gas as reference; if another gas is used, conversion coefficient and a simple formula (on the diagram) transform the gas output to a methane equivalent (refer to figure A). Please note that the gas train dimensions must take into account the back pressure of the combustion chamber during operations.

Control of the pressure drop in an existing gas line or selecting a new gas supply line.
The methane output equivalent is determined by the formula fig. A on the diagram and the conversion coefficient.

Once the equivalent output has been determined on the delivery scale (\dot{V}), shown at the top of the diagram, move vertically downwards until you cross the line that represents the pipe diameter; at this point, move horizontally to the left until you meet the line that represents the pipe length. Once this point is established you can verify, by moving vertically downwards, the pipe pressure drop on the bottom scale (mbar).

By subtracting this value from the pressure measured on the gas meter, the correct pressure value will be found for the choice of gas train.

- Example:**
- gas used G25
 - gas output 9.51 mc/h
 - pressure at the gas meter 20 mbar
 - gas line length 15 m
 - conversion coefficient 0.62 (see figure A)

- equivalent methane output $\dot{V} = \left[\frac{9.51}{0.62} \right] = 15.34 \text{ mc/h}$

- once the value of 15.34 has been identified on the output scale (\dot{V}), moving vertically downwards you cross the line that represents 1" 1/4 (the chosen diameter for the piping);
- from this point, move horizontally to the left until you meet the line that represents the length of 15 m of the piping;
- move vertically downwards to determine a value of 1.4 mbar in the pressure drop bottom scale;
- subtract the determined pressure drop from the meter pressure, the correct pressure level will be found for the choice of gas train;
- correct pressure = (20-1.4) = 18.6 mbar

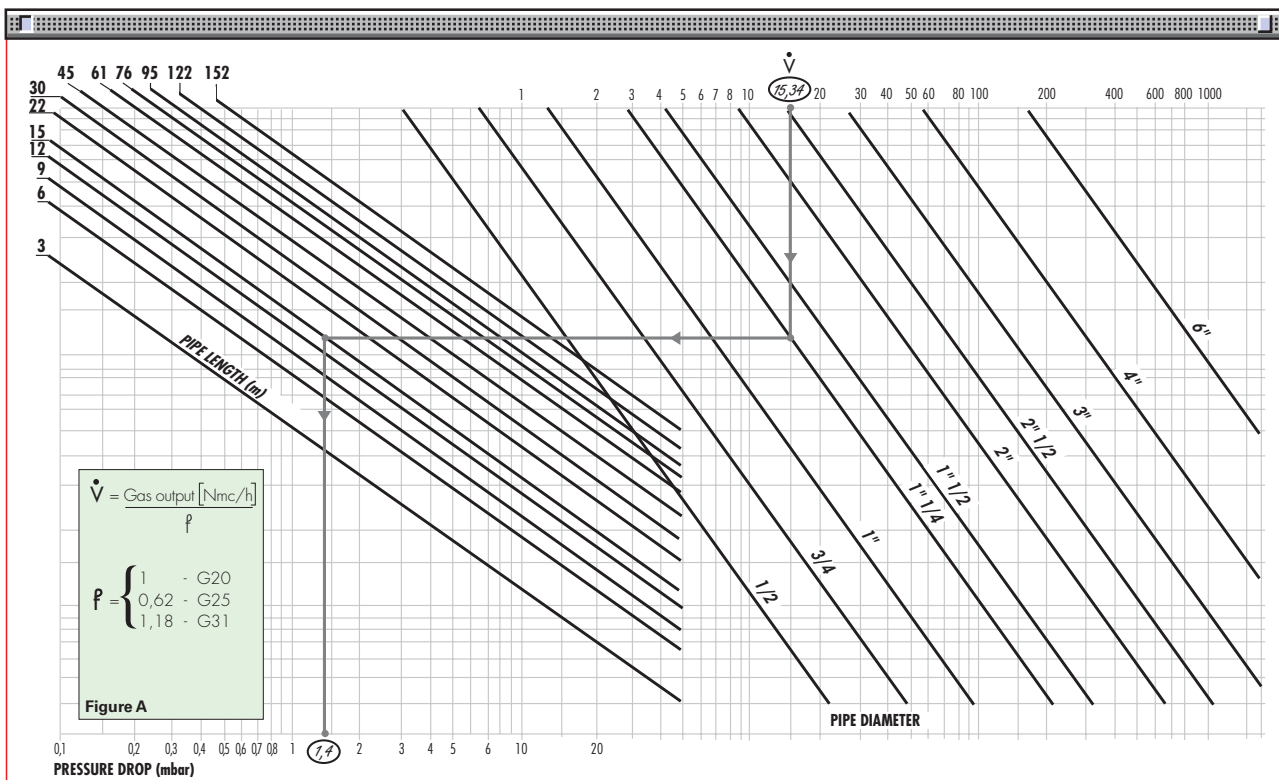

VENTILATION



Example of the servomotor for air/gas setting

The ventilation circuit produces low noise levels with high performance pressure and air output, in despite of the compact dimensions.

On RS 45 - 68 - 120/M BLU models, the use of reverse curve blades and sound-proofing material keeps noise level very low. In the RS 25 - 35 - 160 - 200/M BLU models, noise has been reduced by the special design of the air suction circuit.

A variable profile cam connects the fuel and air regulations, ensuring high fuel efficiency at all firing ranges.

A minimum air pressure switch stops the burner when there is an insufficient quantity of air at the combustion head.

Models with a special control panel and servomotor are suitable for steam generators which conform to TRD 604 (Germany) and NBN (Belgium).

The RS 25/M BLU and RS 35/M BLU are realised with a new structure made by an innovative technology based on a new fibreglass reinforced polyamide material, with high thermal and mechanical characteristics, instead of the traditional aluminium.

This allows big advantages in terms of lay-out rationalisation, weight and dimensions reduction. In order to guarantee the correct exercise temperature for the internal burner components in every working conditions, the new structure includes an innovative patented cooling technology.

Between the burner front base and the reinforcing steel front plate, had been create an air cavity offering an high thermal insulation against the front boiler reflection heat, and to further improve the insulation efficiency the innovative **HCS (Housing Cooling System)** technology had been developed. Inside the front base cavity an air circulation is activated with continuous air volume refresh to obtain an active cooling system and avoid any heat transfer to the electrical component housing.



Example of HCS (Housing Cooling System) working concept

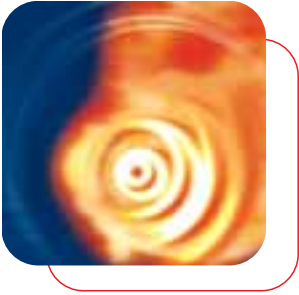

COMBUSTION HEAD

Different lengths of the combustion head can be chosen for the RS/M BLU series of burners.

The choice depends on the thickness of the front panel and the type of boiler.

Depending on the type of generator, check that the penetration of the head into the combustion chamber is correct.

The internal positioning of the combustion head can easily be adjusted to the maximum defined output by adjusting a screw fixed to the flange.



Example of a RS 45/M BLU burner combustion head



Example of a RS 160/M BLU burner combustion head

Dimensions of the flame

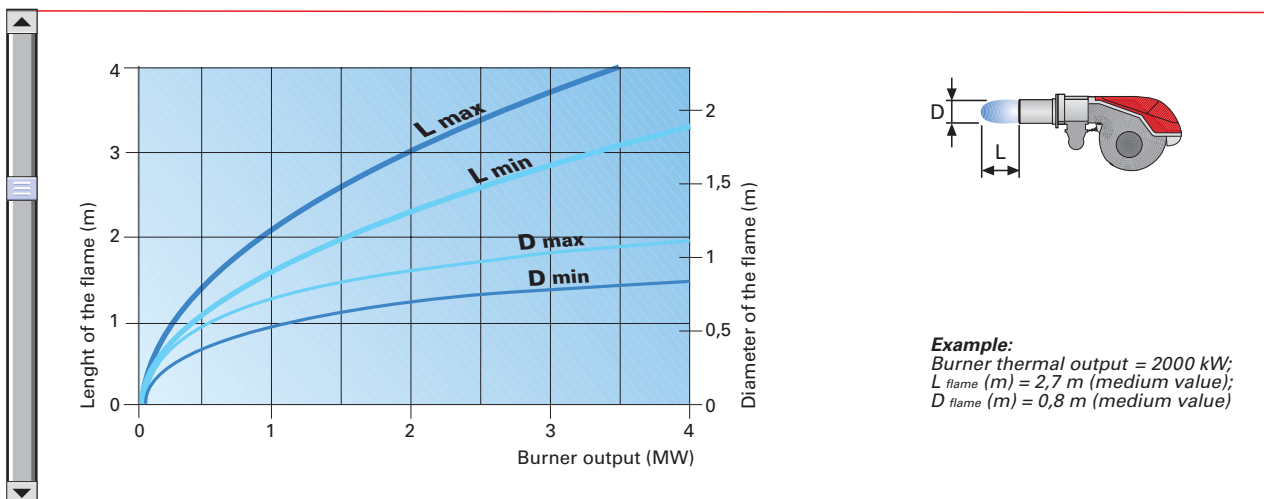

OPERATION



BURNER OPERATION MODE

The RS/M BLU series of burners can have “two-stage progressive” or “modulating” operation.

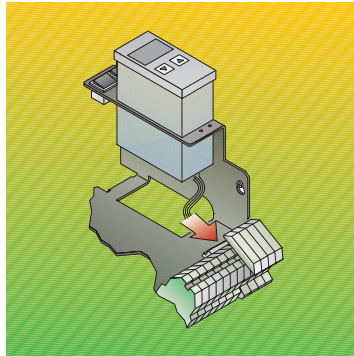

Example of a regulator

“Two-stage progressive” operation

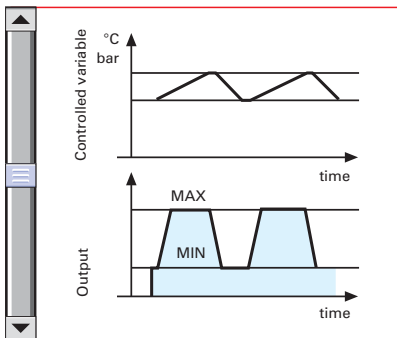

Picture A

On “two-stage progressive” operation, the burner gradually adapts the output to the requested level, by varying between two pre-set levels (see picture A).

On “modulating” operation, normally required in steam generators, in superheater boilers or diathermic oil burners, a specific regulator and probes are required. These are supplied as accessories that must be ordered separately. The burner can work for long periods at intermediate output levels (see picture B).

“Modulating” operation

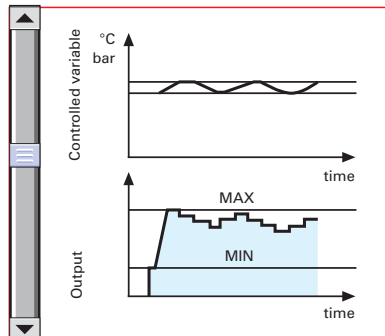

Picture B



All RS/M BLU series burners are fitted with a new microprocessor control panel for the supervision during intermittent operation.

For helping the commissioning and maintenance work, there are two main elements:



The lock-out reset button is the central **operating element** for resetting the burner control and for activating / deactivating the diagnostic functions.



The multi-color LED is the central **indication element** for visual diagnosis and interface diagnosis.

Both elements are located under the transparent cover of lock-out reset button, as showed below.

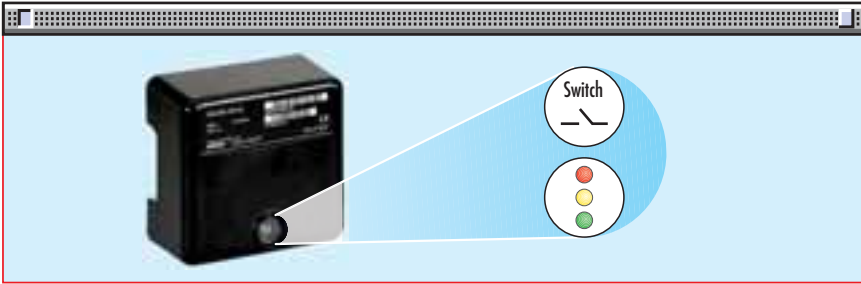

There are two diagnostic choices, for indication of operation and diagnosis of fault cause:

- visual diagnosis:

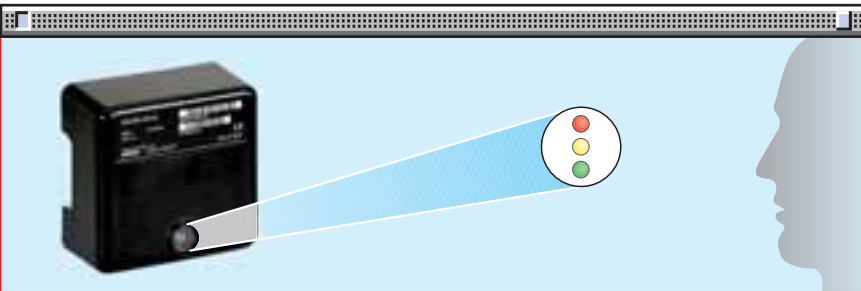

- interface diagnosis:



by the interface adapter and a PC with dedicated software or by a predisposed flue gas analyzer (see paragraph accessories).

Indication of operation:

Color code table	
Operation status	Color code table
Stand-by	○ ○ ○ ○ ○ ○ ○ ○
Pre-purging	☀ ☀ ☀ ☀ ☀ ☀ ☀ ☀
Ignition phase	☀ ○ ☀ ○ ☀ ○ ☀ ○
Flame OK	☀ ☀ ☀ ☀ ☀ ☀ ☀ ☀
Poor flame	☀ ○ ☀ ○ ☀ ○ ☀ ○
Undervoltage, built-in fuse	☀ ☀ ☀ ☀ ☀ ☀ ☀ ☀
Fault, alarm	☀ ☀ ☀ ☀ ☀ ☀ ☀ ☀
Flame simulation	☀ ☀ ☀ ☀ ☀ ☀ ☀ ☀

In normal operation, the various status are indicated in the form of colour codes according to the table below.

The interface diagnosis (with adapter) can be activated by pressing the lock-out button for > 3 seconds.

○ LED off



Diagnosis of fault causes:

After lock-out has occurred, the red signal lamp is steady on. In this status, the visual fault diagnosis according to the error code table can be activated by pressing the lock-out reset button for > 3 seconds. The interface diagnosis (with adapter) can be activated by pressing again the lock-out button for > 3 seconds.

The flashing of red LED are a signal with this sequence:

(e.g. signal with n° 3 flashes – faulty air pressure monitor)



Error code table	
Possible cause of fault	Flash code
No establishment of flame at the end of safety time : - faulty or soiled fuel valves - faulty or soiled flame detector - poor adjustment of burner, no fuel - faulty ignition equipment	2 flashes
Faulty air pressure monitor	3 flashes
Extraneous light or simulation of flame on burner start up	4 flashes
Flame presence during pre-purging	5 flashes
Loss of flame during operation : - faulty or soiled fuel valves - faulty or soiled flame detector - poor adjustment of burner	7 flashes
Minimum air pressure switch opens during operation	18 flashes
Wrong electrical connections	19 flashes
Faulty control box	20 flashes

START UP CYCLE

RS 25/M - 35/M - 45/M BLU

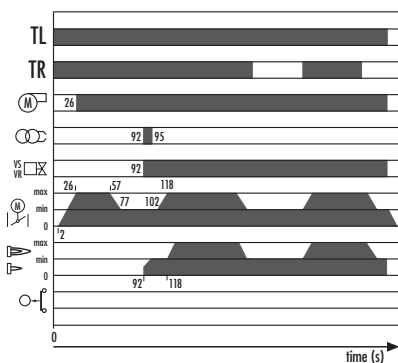

- 0" The TL remote control closes.
- 2" - 26" The servomotor opens the air-damper.
- 26" - 57" Pre-ventilation with air delivery at max output.
- 57" - 77" The air damper and the gas butterfly valve are positioned on MIN output.
- 92" The ignition electrode sparks.
Firing : the VS safety valve and the VR adjustment valve open.
- 118" The start up cycle of the control box is concluded.

RS 68/M - 120/M - 160 - 200/M BLU

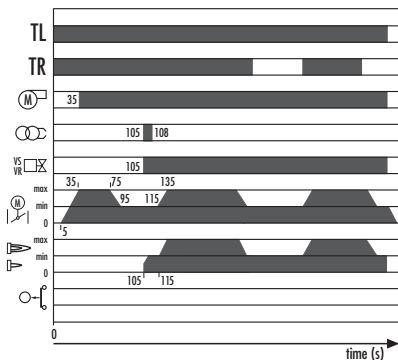

- 0" The TL remote control closes.
- 5" - 35" The servomotor opens the air-damper.
- 35" - 75" Pre-ventilation with air delivery at max output.
- 75" - 95" The air damper and the gas butterfly valve are positioned on MIN output.
- 105" The ignition electrode sparks.
Firing : the VS safety valve and the VR adjustment valve open.
- 115" The start up cycle of the control box is concluded.



BURNER WIRING



All models of the RS/M BLU burner series have an easily accessible control panel for the electrical components housing and wiring. In particular the new RS 25 - 35/M BLU models, thanks to the new structure concept, have an extremely clean electrical layout to optimise the commissioning and maintenance speed.

On these models the electrical connections are done by a Plug&Socket system, accessible from the external of the cover, and some of the main components as the servomotor, the air pressure switch, the electronic regulator (accessory) and the gas max pressure switch (accessory) are connected to the burner electrical wiring trough plugs & sockets system in order to facilitate the connection in case of maintenance.

The electrical wiring of all RS/M BLU burner models are very easy to do following the wiring diagrams included in the instruction handbook. Electrical connections must be made by qualified and skilled personnel, according to the local norms.



Example of the terminal board for electrical connections for the RS 68-120-160-200/M BLU models



Example of electrical components housing and Plug&Socket system for electrical connection of RS 25-35/M BLU

The following table shows the supply lead sections and the type of fuse to be used.

Model	▼ RS 25/M BLU		▼ RS 35/M BLU		▼ RS 45/M BLU		▼ RS 68/M BLU		▼ RS 120/M BLU		▼ RS 160/M BLU	
	230V		230V	400V	230V		230V	400V	230V	400V	230V	400V
F A	T6		T6	T6	T6		T16	T10	T16	T10	T25	T20
L mm ²	1,5		1,5	1,5	1,5		1,5	1,5	1,5	1,5	2,5	2,5

Model	▼ RS 200/M BLU	
	230V	
	400V	
F A	32A aM - 40A gG	16A aM - 32A gG
L mm ²	6	4

EMISSIONS

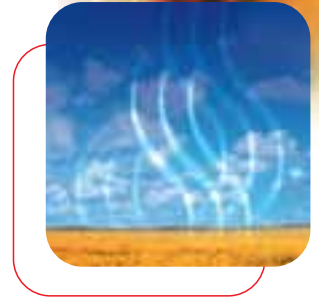

The emissions have been measured in various models at maximum output, according to EN 676 standard.

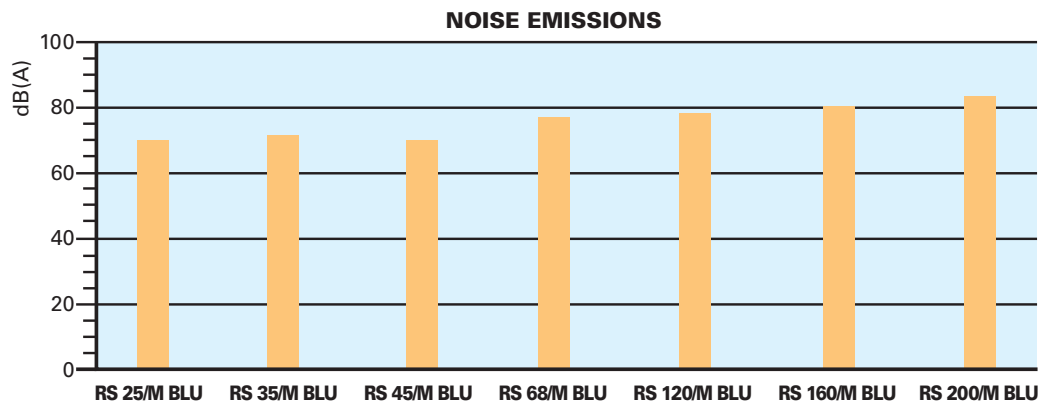
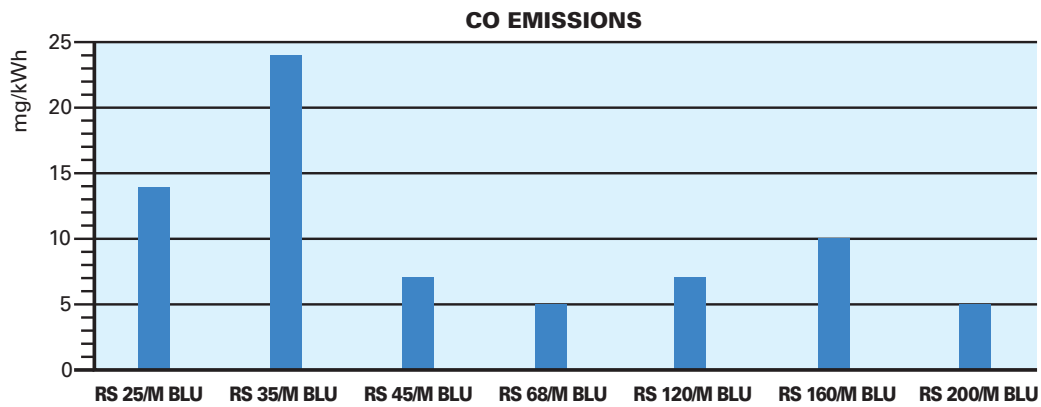
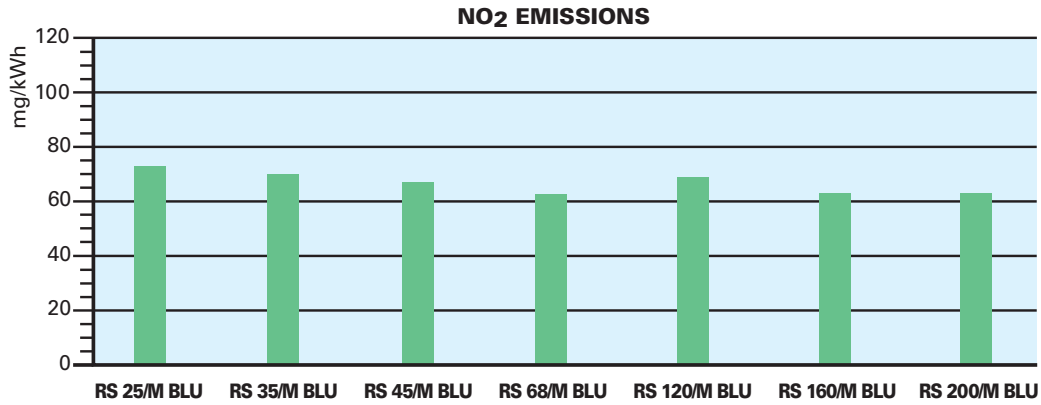

The noise emission have been measured at maximum output.



The RS/M BLU series combustion heads reduce polluting emissions thanks to their special design which optimises the air fuel mix.

Combustion head operating diagram of RS 25/M - 35/M BLU models

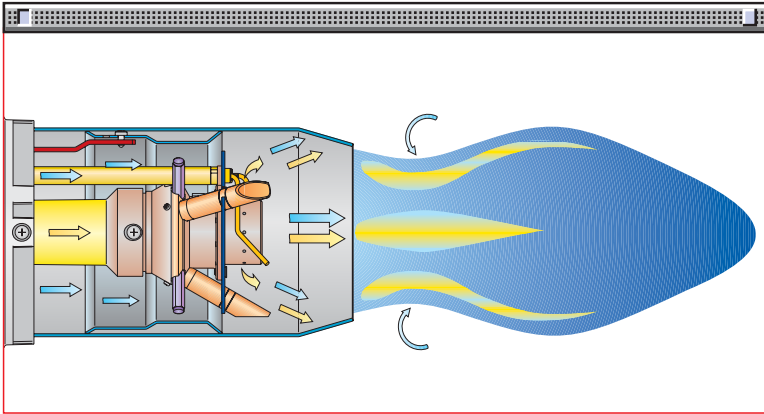

The RS 25/M - 35/M - 45/M BLU models have an oblique radial pipe distributor through which gas is injected directly into the passing air flow for a perfect distribution. This prevents no homogeneous concentrations in the flame with areas of high oxidation; part of the premixed gas/air is injected into the centre of the flame.

These methods produce a very stable flame with gradual and progressive combustion as the flame develops, thus giving polluting emission values below even the most restrictive norm values.

Combustion head operating diagram of RS 45/M BLU model

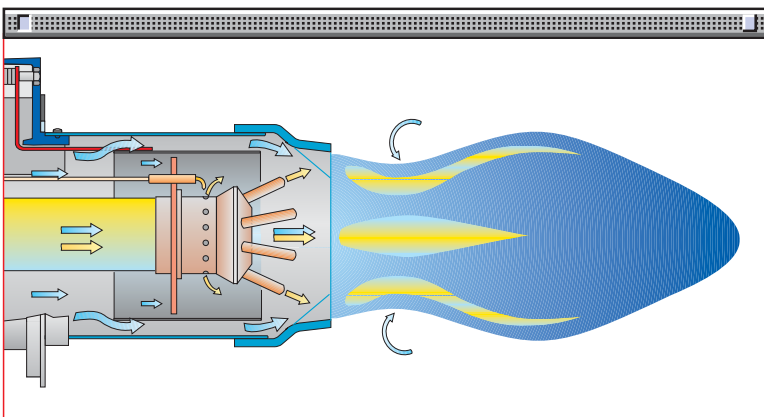

Combustion head operating diagram of RS 68/M - 120/M - 160/M - 200/M BLU models

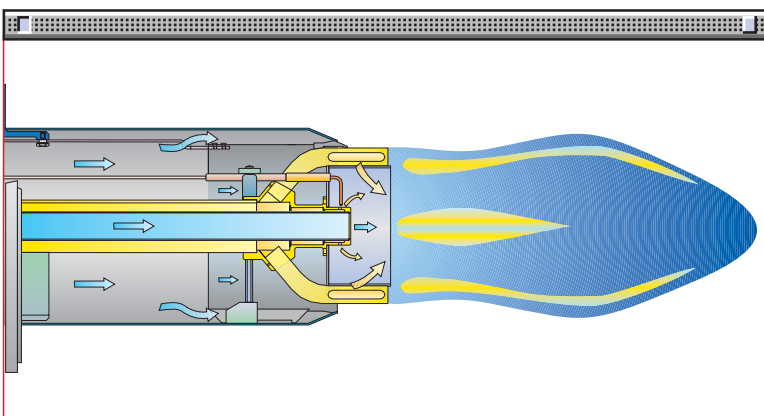

In RS 68/M - 120/M - 160/M - 200/M BLU models part of the gas is distributed through outlets which are perpendicular to the air flow, while the remaining gas is injected directly into the centre of the flame. This prevents no homogeneous concentrations in the flame with areas of high oxidation, producing very stable flame with gradual and progressive combustion as the flame develops, thus giving polluting emission values below even the most restrictive norm values.

OVERALL DIMENSIONS (mm)



BURNER

RS 25/M - 35/M BLU

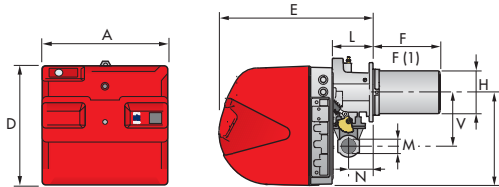

RS 45/M BLU

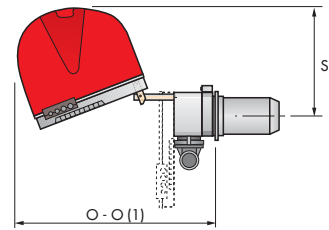
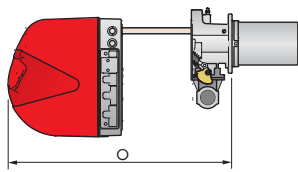
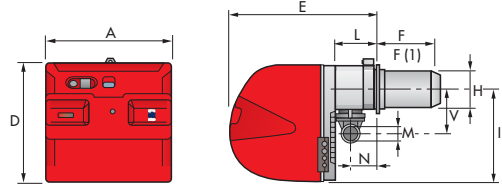

RS 68/M - 120/M - 160/M - 200/M BLU

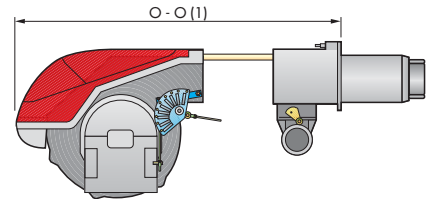
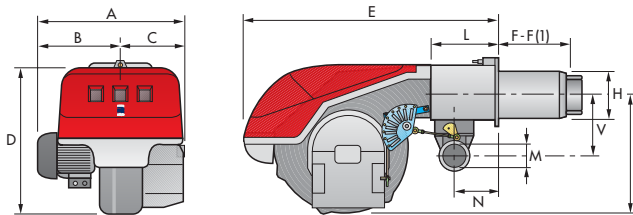

Model	A	B	C	D	E	F - F(1)	H	I	L	M	N	O - O(1)	S	V
▶ RS 25/M BLU	442	-	-	422	508	230 - 365	140	305	138	1" 1/2	84	780 - -	-	177
▶ RS 35/M BLU	442	-	-	422	508	230 - 365	152	305	138	1" 1/2	84	780 - -	-	177
▶ RS 45/M BLU	476	-	-	474	580	229 - 354	160	352	164	1" 1/2	108	810 - 810	367	168
▶ RS 68/M BLU	527	312	215	555	840	255 - 390	189	430	214	2"	134	1161 - 1296	-	221
▶ RS 120/M BLU	553	338	215	555	840	255 - 390	189	430	214	2"	134	1161 - 1296	-	221
▶ RS 160/M BLU	671	366	305	555	863	373 - 503	221	436	221	2"	141	1442 - 1587	-	264
▶ RS 200/M BLU	737	432	305	555	863	373 - 503	221	436	221	2"	141	1442 - 1587	-	264

(1) Length with extended combustion head

BURNER - BOILER MOUNTING FLANGE

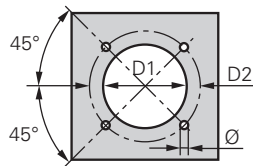

Model	D1	D2	Ø
▶ RS 25/M BLU	160	224	M8
▶ RS 35/M BLU	160	224	M8
▶ RS 45/M BLU	165	224	M8
▶ RS 68/M BLU	195	275-325	M12
▶ RS 120/M BLU	195	275-325	M12
▶ RS 160/M BLU	230	325-368	M16
▶ RS 200/M BLU	230	325-368	M16

PACKAGING

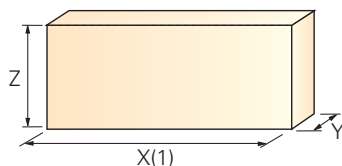

Model	X(1)	Y	Z	kg
▶ RS 25/M BLU	1000	485	500	39
▶ RS 35/M BLU	1000	485	500	40
▶ RS 45/M BLU	1015	500	630	48
▶ RS 68/M BLU	1405	700	660	78
▶ RS 120/M BLU	1405	700	660	84
▶ RS 160/M BLU	1405-1420	1000	660	89
▶ RS 200/M BLU	1405-1420	1000	660	125

(1) dimension with standard and extended head





INSTALLATION DESCRIPTION

Installation, start up and maintenance must be carried out by qualified and skilled personnel. All operations must be performed in accordance with the technical handbook supplied with the burner.

BURNER SETTING

- ▶ All the burners have slide bars, for easier installation and maintenance.
- ▶ After drilling the boilerplate, using the supplied gasket as a template, dismantle the blast tube from the burner and fix it to the boiler.
- ▶ Adjust the combustion head.
- ▶ Fit the gas train, choosing this on the basis of the maximum output of the boiler and considering the enclosed diagrams.
- ▶ Refit the burner casing to the slide bars.
- ▶ Close the burner, sliding it up to the flange.

ELECTRICAL CONNECTIONS AND START UP

- ▶ Make the electrical connections to the boiler following the wiring diagrams included in the instruction handbook.
- ▶ Turn the motor to check rotation direction (if it is a three-phase motor).
- ▶ Perform a first ignition calibration on the gas train.
- ▶ On start up, check:
 - Gas pressure at the combustion head (to max. and min. output)
 - Combustion quality, in terms of unburned substances and excess air.

BURNER MAINTENANCE

- ▶ The maintenance of RS/M BLU burners is very simple thanks to the sliding bars system that allows an easy access to the internal components.
- ▶ In particular the RS 25-35/M BLU models have a new sliding bars system to make easier the access to the combustion head.
- ▶ The RS 160-200/M BLU have new reinforced sliding bars that make very strong the burner structure during maintenance.

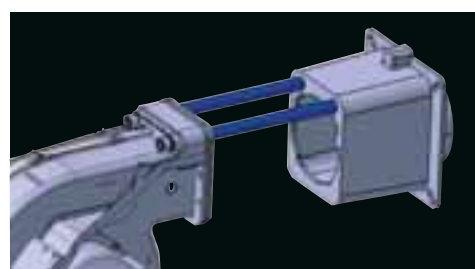

BURNER ACCESSORIES



Extended head kit

“Standard head” burners can be transformed into “extended head” versions, by using the special kit. The KITS available for the various burners, giving the original and the extended lengths, are listed below.

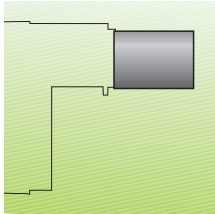

Extended head kit			
Burner	Standard head length (mm)	Extended head length (mm)	Kit code
RS 25/M BLU	230	365	3010430
RS 35/M BLU	230	365	3010431
RS 45/M BLU	229	354	3010240
RS 68/M - 120/M BLU	255	390	3010177
RS 160/M BLU	373	503	3010442
RS 200/M BLU	373	503	3010474

Spacer kit

If burner head penetration into the combustion chamber needs reducing, varying thickness spacers are available, as given in the following table:



Spacer kit		
Burner	Spacer thickness S (mm)	Kit code
RS 25/M - 35/M - 45/M BLU	90	3010095
RS 68/M - 120/M BLU	135	3010129
RS 160-200/M BLU	110	3000722

Continuous ventilation kit

If the burner requires continuous ventilation in the stages without flame, a special kit is available as given in the following table:



Continuous ventilation kit	
Burner	Kit code
RS 25 - 35/M BLU	3010449
RS 45 - 68 - 120 - 160 - 200/M BLU	3010094

Sound proofing box

If noise emission needs reducing even further, sound-proofing boxes are available, as given in the following table:



Sound proofing box			
Burner	Box type	Average noise reduction [dB(A)](*)	Box code
RS 25/M - 35/M - 45/M BLU	C1/3	10	3010403
RS 68/M - 120/M - 160/M - 200/M BLU	C4/5	10	3010404

(*) according to EN 15036-1 standard



Head kit for “reverse flame chamber”

In certain cases, the use of the burner on reverse flame boilers can be improved by using an additional Pipes Kit.



Head kit for “reverse flame chamber”	
Burner	Code
RS 68/M BLU	3010247
RS 120/M BLU	3010248
RS 160/M BLU	3010249
RS 200/M BLU	3010475

Accessories for modulating operation

To obtain modulating operation, the RS/M BLU series of burners requires a regulator with three point outlet controls. On RS 25/M - 35/M BLU the regulator is connected to the burner electrical wiring by plug-in system in order to make the connection easier and faster.

The following table lists the accessories for modulating operation with their application range.



Regulator		
Burner	Type	Code
RS 25/M - 35/M BLU	RWF 40	3010417
RS 45/M - 68/M - 120/M - 160/M BLU	RWF 40	3010212
RS 200/M BLU	RWF 40	3010414

The relative temperature or pressure probes fitted to the regulator must be chosen on the basis of the application.



Probe		
Type	Range (°C) (bar)	Code
Temperature PT 100	-100 ÷ 500°C	3010110
Pressure 4 ÷ 20 mA	0 ÷ 2,5 bar	3010213
Pressure 4 ÷ 20 mA	0 ÷ 16 bar	3010214

Modulating operation can also be obtained with an analog control signal converter and a feedback three-pole potentiometer.

Alternatively, the potentiometer can be used to check the servomotor position.



Analog control signal converter		
Burner	Type (input signal)	Code
RS 25/M - 35/M BLU	0/2 - 10 V (impedance 200 K Ω) 0/4 - 20 mA (impedance 250 Ω)	3010410
RS 45/M - 68/M BLU RS 120/M - 160/M BLU	0/2 - 10 V (impedance 200 K Ω) 0/4 - 20 mA (impedance 250 Ω)	on demand
RS 200/M BLU	0/2 - 10 V (impedance 200 K Ω) 0/4 - 20 mA (impedance 250 Ω)	3010415

Depending on the servomotor fitted to the burner, a three-pole potentiometer (1000 Ω) can be installed to check the position of the servomotor. The KITS available for the various burners are listed below.



Potentiometer kit	
Burner	Code
RS 25/M - 35/M BLU	3010420
RS 45/M BLU	3010109
RS 68/M - 120/M - 160/M BLU	3010021
RS 200/M BLU	3010416



Ground fault interrupter kit

A "Ground fault interrupter kit" is available as a safety device for electrical system fault.



Ground fault interrupter kit	
Burner	Kit code
RS 25/M - 35/M BLU	3010448

Gas max pressure switch

If necessary a Gas max pressure Switch kit is available and connectable to the burner electrical wiring trough Plugs & Sockets system.

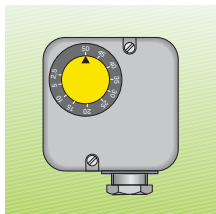

Gas max pressure switch	
Burner	Code
RS 25/M - 35/M BLU	3010418

Volt free contact kit

A volt free contact kit is available for installation onto the burner. It can be used for a remote interface between burner operating signals. Every burner can be equipped with a single kit for a remote check of the flame presence signal or the burner lockout indication.



Volt free contact kit	
Burner	Kit code
RS 25/M - 35/M BLU	3010419

PC interface kit

To connect the flame control panel to a personal computer for the transmission of operation, fault signals and detailed service information, an interface adapter with PC software is available.



PC interface kit	
Burner	Kit code
RS 25/M - 35/M - 45/M - 68/M - 120/M - 160/M - 200/M BLU	3002719

DN80 gas flange kit

To modify the standard 2" burner gas input connection in to DN80 connection, a specific gas flange is available.

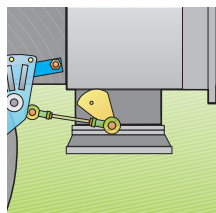

DN80 gas flange kit	
Burner	Kit code
RS 68/M - 120/M - 160/M - 200/M BLU	3010439





Post-ventilation kit

To have 20 s ventilation after opening of thermostats chain, a special kit is available.

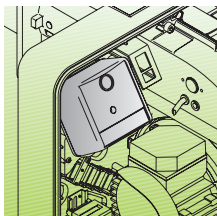

Post-ventilation kit	
Burner	Kit code
RS 25/M - 35/M BLU	3010451

Hours counter kit

To measure the burner working time a hour counter kit is available.

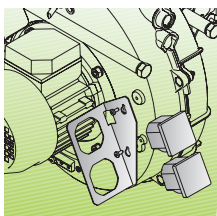

Hours counter kit	
Burner	Kit code
RS 25/M - 35/M BLU	3010450

LPG kit

For burning LPG gas, a special kit is available to be fitted to the combustion head on the burner, as given in the following table:

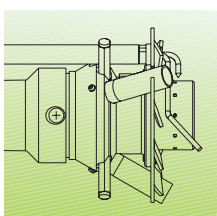









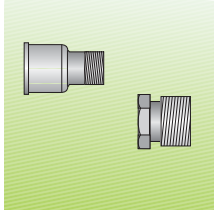















LPG kit		
Burner	Kit code for 'standard head'	Kit code for 'extended head'
RS 25/M BLU	3010423	3010423
RS 35/M BLU	3010424	3010424

GAS TRAIN ACCESSORIES

Adapters

When the diameter of the gas train is different from the set diameter of the burners, an adapter must be fitted between the gas train and the burner. The following table lists the adapters for various burners.



Adapters			
Burner	Gas train	Dimensions	Adapter code
RS 25/M BLU	MBD 405 - 407 - 410	3/4"  1" 1/2	3000824
	MBD 420	2"  1" 1/2	3000822
RS 35/M BLU	MBD 405 - 407 - 410	3/4"  1" 1/2	3000824
	MBD 420	2"  1" 1/2	3000822
RS 45/M BLU	MBD 407 - 410	3/4"  1" 1/2	3000824
	MBD 420	2"  1" 1/2	3000822
RS 68/M BLU	MBD 412 - 415	1" 1/2  2"	3000843
RS 120/M BLU	MBD 415	1" 1/2  2"	3000843
	MBC 1900	DN 65  2" 1/2  1" 1/2  2"	3000825
RS 160/M BLU	MBD 415	1" 1/2  2"	3000843
	MBC 1900	DN 65  2" 1/2  1" 1/2  2"	3000825
	MBC 3100	DN 80  2" 1/2  2"	3000826
RS 200/M BLU	MBD 415	1" 1/2  2"	3000843
	MBC 1900	DN 65  2" 1/2  1" 1/2  2"	3000825
	MBC 3100	DN 80  2" 1/2  2"	3000826

Seal control kit

To test the valve seals on the gas train, a special “seal control kit” is available. The valve seal control device is compulsory (EN 676) on gas trains to burners with a maximum output over 1200 kW. The seal control is type VPS 504.



Seal control kit	
Gas train	Kit code
MBD type	3010123
MBC type	3010367

Stabiliser spring for multibloc composed

Accessory springs are available to vary the pressure range of the gas train composed. The following table shows these accessories with their application range.



Stabiliser springs		
Gas train	Spring	Spring code
MBC 1900 SE 65 FC (CT)*	White from 4 to 20 mbar	3010381
	Red from 20 to 40 mbar	3010382
MBC 3100 SE 80 FC (CT)*	Black from 40 to 80 mbar	3010383
	Green from 80 to 150 mbar	3010384

* with and without seal control.

Please refer to the technical manual for the correct choice of spring.

SPECIFICATION



A specific index guides your choice of burner from the various models available in the RS/M BLU series.
Below is a clear and detailed specification description of the product.

DESIGNATION OF SERIES

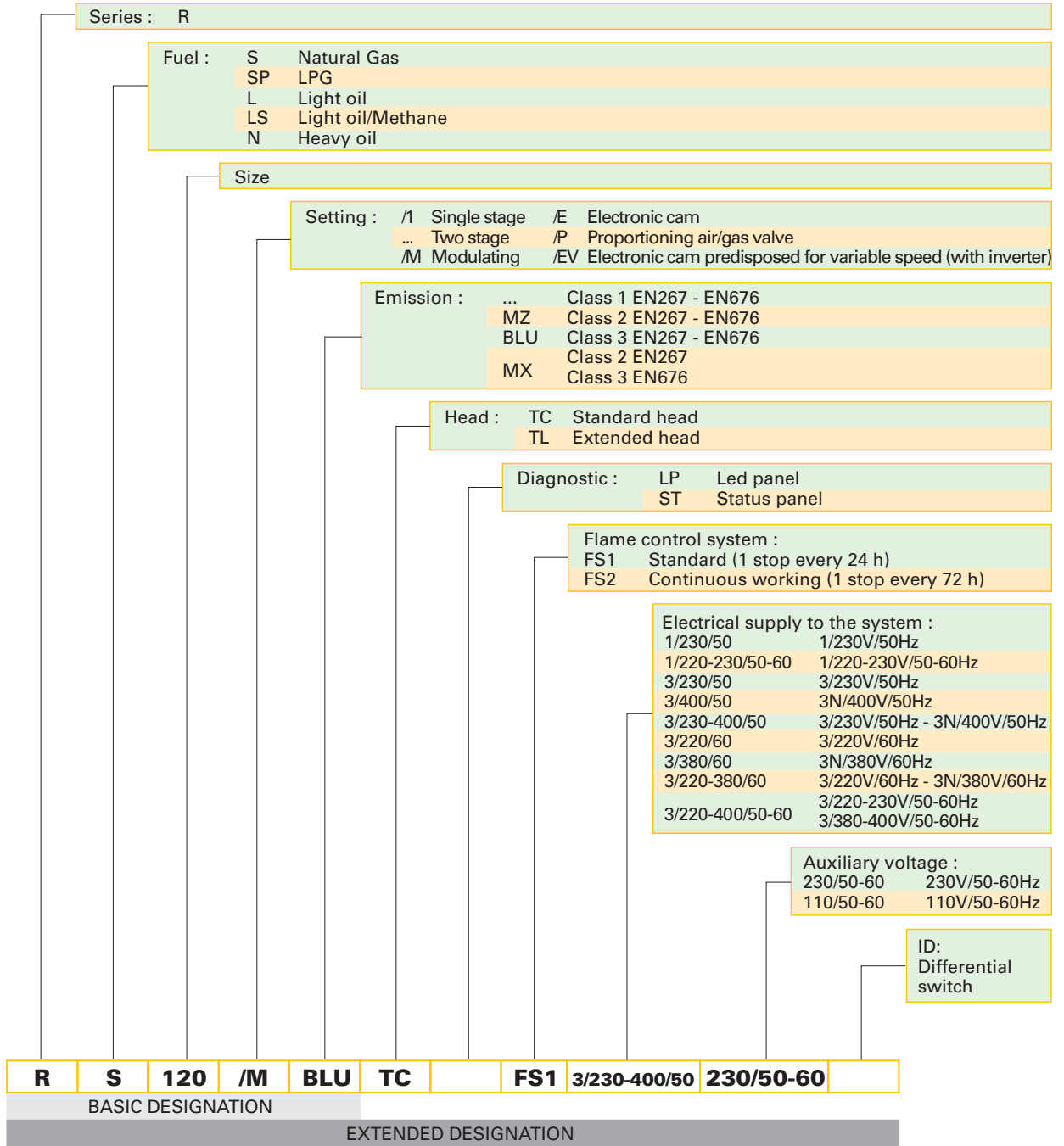



AVAILABLE BURNER MODELS

RS 25/M	BLU	TC	FS1	1/220-230/50-60	220-230/50-60	
RS 25/M	BLU	TL	FS1	1/220-230/50-60	220-230/50-60	
RS 25/M	BLU	TC	FS2	1/220-230/50-60	220-230/50-60	
RS 25/M	BLU	TL	FS2	1/220-230/50-60	220-230/50-60	
RS 35/M	BLU	TC	FS1	1/220-230/50-60	220-230/50-60	
RS 35/M	BLU	TL	FS1	1/220-230/50-60	220-230/50-60	
RS 35/M	BLU	TC	FS1	3/220-400/50-60	220-230/50-60	
RS 35/M	BLU	TL	FS1	3/220-400/50-60	220-230/50-60	
RS 35/M	BLU	TC	FS2	1/220-230/50-60	220-230/50-60	
RS 35/M	BLU	TL	FS2	1/220-230/50-60	220-230/50-60	
RS 35/M	BLU	TC	FS2	3/220-400/50-60	220-230/50-60	
RS 35/M	BLU	TL	FS2	3/220-400/50-60	220-230/50-60	
RS 45/M	BLU	TC	FS1	1/230/50	230/50-60	
RS 45/M	BLU	TL	FS1	1/230/50	230/50-60	
RS 45/M	BLU	TC	FS2	1/230/50	230/50-60	
RS 45/M	BLU	TL	FS2	1/230/50	230/50-60	
RS 45/M	BLU	TC	FS1	1/230/50	230/50-60	ID
RS 45/M	BLU	TL	FS1	1/230/50	230/50-60	ID
RS 45/M	BLU	TC	FS2	1/230/50	230/50-60	ID
RS 45/M	BLU	TL	FS2	1/230/50	230/50-60	ID
RS 68/M	BLU	TC	FS1	3/230-400/50	230/50-60	
RS 68/M	BLU	TL	FS1	3/230-400/50	230/50-60	
RS 68/M	BLU	TC	FS2	3/230-400/50	230/50-60	
RS 68/M	BLU	TL	FS2	3/230-400/50	230/50-60	
RS 120/M	BLU	TC	FS1	3/230-400/50	230/50-60	
RS 120/M	BLU	TL	FS1	3/230-400/50	230/50-60	
RS 120/M	BLU	TC	FS2	3/230-400/50	230/50-60	
RS 120/M	BLU	TL	FS2	3/230-400/50	230/50-60	
RS 160/M	BLU	TC	FS1	3/230-400/50	230/50-60	
RS 160/M	BLU	TL	FS1	3/230-400/50	230/50-60	
RS 160/M	BLU	TC	FS2	3/230-400/50	230/50-60	
RS 160/M	BLU	TL	FS2	3/230-400/50	230/50-60	
RS 200/M	BLU	TC	FS1	3/230-400/50	230/50-60	
RS 200/M	BLU	TL	FS1	3/230-400/50	230/50-60	
RS 200/M	BLU	TC	FS2	3/230-400/50	230/50-60	
RS 200/M	BLU	TL	FS2	3/230-400/50	230/50-60	

Other versions are available on request

PRODUCT SPECIFICATION

RS 25/M - 35/M BLU models

Burner:

Monoblock forced draught LOW NO_x gas burner with two stage progressive or modulating operation, with a specific kit, fully automatic, made up of:

- air suction circuit
- high performance fan with straight blades
- air damper for air flow setting and butterfly valve for regulating fuel output controlled by a servomotor with variable cam
- starting motor at 2800 rpm, single-phase / 220-230V / 50-60Hz or three-phase 380-400V / 50-60Hz
- low emission combustion head, that can be set on the basis of required output, fitted with:
 - stainless steel end cone, resistant to corrosion and high temperatures
 - ignition electrodes
 - ionisation probe
 - gas distributor
 - flame stability disk
- exclusive patented HCS (Housing Cooling System) with high thermal insulation and air circulation with continuous air volume refresh for an active cooling system and avoid heat transfer to the electrical component housing
- minimum air pressure switch stops the burner in case of insufficient air quantity at the combustion head
- microprocessor-based flame control panel, with diagnostic functions
- plugs and sockets for electrical connection, accessible from the external of the cover
- burner on/off selection switch
- manual or automatic output increase/decrease selection switch
- flame inspection window
- slide bars for easier installation and maintenance
- protection filter against radio interference
- IP 40 electric protection level.

Gas train:

Fuel supply line in the MULTIBLOC configuration (from a diameter of 3/4" until a diameter of 2") fitted with:

- MULTIBLOC with integrated filter
- Minimum gas pressure switch

Conforming to:

- 89/336/EC (2004/108/EC) directive (electromagnetic compatibility)
- 73/23/EC directive (low voltage)
- 92/42/EC directive (performance)
- 90/396/EC directive (gas)
- EN 676 (gas burners).

Standard equipment:

- 1 gas train gasket
- 1 flange gasket
- 4 screws for fixing the flange
- 1 thermal screen
- 4 screws for fixing the burner flange to the boiler
- 3 plugs for electrical connection (RS 25-35/M BLU single-phase)
- 4 plugs for electrical connection (RS 35/M BLU three-phase)
- instruction handbook for installation, use and maintenance
- spare parts catalogue.

Available accessories to be ordered separately:

- Extended head kit
- Spacer kit
- Sound-proofing box
- RWF 40 output regulator
- Temperature probe -100 ÷ 500°C
- Pressure probe 0 ÷ 2.4 bar
- Pressure probe 0 ÷ 16 bar
- Analog control signal converter
- Potentiometer kit for the servomotor
- Ground fault interrupter kit
- Gas max pressure switch
- Volt free contact kit
- PC interface kit
- Gas train adapter
- Seal control kit
- Stabiliser spring
- Post-ventilation kit
- Hours counter kit
- LPG kit.



▶ PRODUCT SPECIFICATION

RS 45/M - 68/M - 120/M - 160/M - 200/M BLU models

Burner:

Monoblock forced draught LOW NO_x gas burner with two stage progressive or modulating operation, with a specific kit, fully automatic, made up of:

- air suction circuit lined with sound-proofing material
- fan with reverse curve blades (straight blades on the 160-200/M BLU models) high performance with low sound emissions
- air damper for air flow setting and butterfly valve for regulating fuel output controlled by a servomotor with variable cam
- starting motor at 2800 rpm, three-phase 400V with neutral, 50Hz (single-phase, 230V and 50Hz for the 45/M BLU model)
- low emission combustion head, that can be set on the basis of required output, fitted with:
 - stainless steel end cone, resistant to corrosion and high temperatures
 - ignition electrodes
 - ionisation probe
 - gas distributor
 - flame stability disk
- maximum gas pressure switch to stop the burner in the case of excess pressure on the fuel supply line
- minimum air pressure switch stops the burner in case of insufficient air quantity at the combustion head
- microprocessor-based flame control panel, with diagnostic functions
- burner on/off selection switch
- manual or automatic output increase/decrease selection switch
- flame inspection window
- slide bars for easier installation and maintenance
- protection filter against radio interference
- IP 44 electric protection level.

Gas train:

Fuel supply line in the MULTIBLOC configuration (from a diameter of 3/4" until a diameter of 2") fitted with:

- MULTIBLOC with integrated filter
- Minimum gas pressure switch

Fuel supply line the COMPOSED configuration (from a diameter of DN 65 until a diameter of DN 80), fitted with:

- Filter
- MULTIBLOC
- Minimum gas pressure switch
- Valve seal control (for output > 1200 kW)

Conforming to:

- 89/336/EC (2004/108/EC) directive (electromagnetic compatibility)
- 73/23/EC directive (low voltage)
- 92/42/EC directive (performance)
- 90/396/EC directive (gas)
- EN 676 (gas burners).

Standard equipment:

- 1 gas train gasket
- 1 flange gasket
- 4 screws for fixing the flange
- 1 thermal screen
- 4 screws for fixing the burner flange to the boiler
- wiring loom fittings for the electrical connection (for RS 45/M BLU model)
- 2 slide bar extensions (for extended head models and RS 160-200/M BLU)
- instruction handbook for installation, use and maintenance
- spare parts catalogue.

Available accessories to be ordered separately:

- Extended head kit
- Spacer kit
- Continuous ventilation kit
- Head kit for reverse flame chamber
- Sound-proofing box
- RWF 40 output regulator
- Temperature probe -100 ÷ 500°C
- Pressure probe 0 ÷ 2.4 bar
- Pressure probe 0 ÷ 16 bar
- Potentiometer kit for the servomotor
- Analog control signal converter
- PC interface kit
- Gas train adapter
- DN80 gas flange kit
- Seal control kit
- Stabiliser spring.





RIELLO S.p.A. - Via Ing. Pilade Riello, 5 - 37045 Legnago (VR) Italy
Tel. ++39.0442630111 - Fax ++39.044221980

Internet: <http://www.rielloburners.com> - E-mail: info@rielloburners.com

Since the Company is constantly engaged in the production improvement, the aesthetic and dimensional features, the technical data, the equipment and the accessories can be changed.
This document contains confidential and proprietary information of RIELLO S.p.A.
Unless authorised, this information shall not be divulged, nor duplicated in whole or in part.