

**Bruciatori di gas ad aria soffziata • Forced draught gas burners • Brûleurs gaz à air soufflé
Gas-Gebläsebrenner • Quemadores de gas de aire soplado**

Gulliver	BS1	COD. 3761158	TIPO/TYP/TYP 911T1	BS3	COD. 3761358	TIPO/TYP/TYP 913T1
	BS2	COD. 3761258	TIPO/TYP/TYP 912T1	BS4	COD. 3761458	TIPO/TYP/TYP 914T1

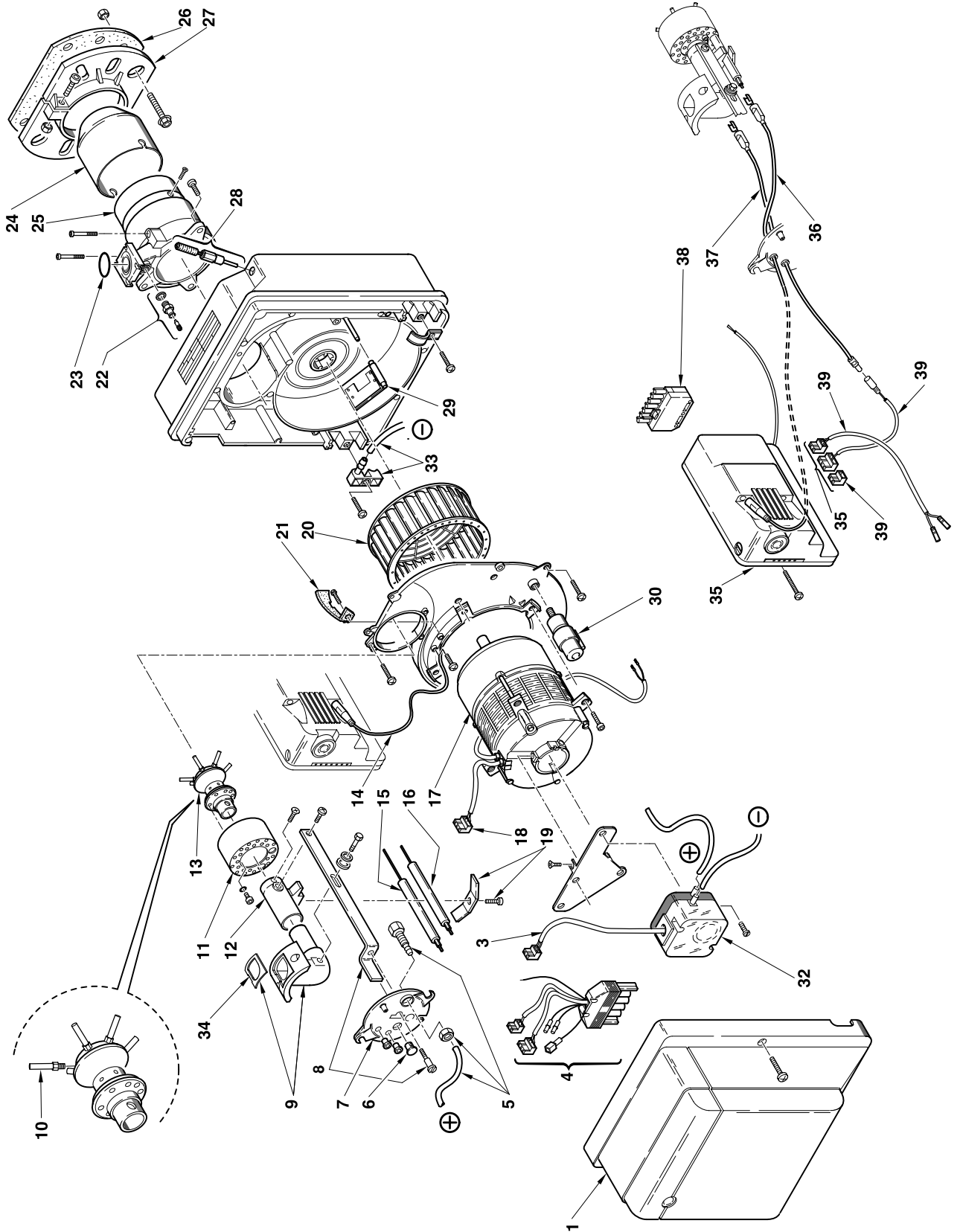

N.	COD.	3761158	3761258	3761358	3761458	DESCRIZIONE	DESCRIPTION	DESCRIPTION	BESCHREIBUNG	DENOMINACIÓN
1	3008080	•				COFANO	COVER	CAPOT	BRENNERHAUBE	ENVOLVENTE
1	3008509		•			COFANO	COVER	CAPOT	BRENNERHAUBE	ENVOLVENTE
1	3007975			•		COFANO	COVER	CAPOT	BRENNERHAUBE	ENVOLVENTE
1	3008496				•	COFANO	COVER	CAPOT	BRENNERHAUBE	ENVOLVENTE
3	3002972	•	•	•		COLLEG. PRESSOSTATO	PRESSURE SWITCH CONN.	CONNEXION PRESSOSTAT	DRUCKWÄCHTER VERBIND.	CABLES PRESOSTATO
4	3002979	•	•	•	•	COLLEGAMENTO	LEAD	CABLE DE CONNEXION	VERBINDUNG	CABLE CONEXIÓN
5	3007982	•	•	•	•	RACCORDO E TUBETTO	CONNECTOR AND TUBE	MAMELON ET TUYAU	NIPPEL UND RÖHRCHEN	RACORD Y TUBO
6	3007458	•	•	•	•	VETRINO	VIEWING PORT	REGARD	VERSCHLUßSTOPFEN	MIRILLA
7	3007613	•				COPERCHIO	COVER	COUVERCLE	DENKEL	TAPA
7	3007491		•			COPERCHIO	COVER	COUVERCLE	DENKEL	TAPA
7	3007642			•	•	COPERCHIO	COVER	COUVERCLE	DENKEL	TAPA
8	3007980	•	•			STAFFA E VITE	BRACKET AND SCREW	SUPPORT ET VIS	DÜSENSTOCKHALTERUNG	SOPORTE ARRAST. Y TORNILLO
8	3007981			•		STAFFA E VITE	BRACKET AND SCREW	SUPPORT ET VIS	DÜSENSTOCKHALTERUNG	SOPORTE ARRAST. Y TORNILLO
8	3008505				•	STAFFA E VITE	BRACKET AND SCREW	SUPPORT ET VIS	DÜSENSTOCKHALTERUNG	SOPORTE ARRAST. Y TORNILLO
9	3007977	•				GOMITO	ELBOW	COUDE	GASSCHLITTEN	CODO
9	3007978		•			GOMITO	ELBOW	COUDE	GASSCHLITTEN	CODO
9	3007979			•	•	GOMITO	ELBOW	COUDE	GASSCHLITTEN	CODO
10	3008000	•				TUBO	TUBE	TUYAU	ROHR	TUBO
10	3008001		•			TUBO	TUBE	TUYAU	ROHR	TUBO
10	3008002			•		TUBO	TUBE	TUYAU	ROHR	TUBO
10	3008504				•	TUBO	TUBE	TUYAU	ROHR	TUBO
11	3007993	•				TAZZA	AIR DIFFUSER	DIFFUSEUR D'AIR	STAUSCHEIBE	DIFUSOR DEL AIRE
11	3007994		•			TAZZA	AIR DIFFUSER	DIFFUSEUR D'AIR	STAUSCHEIBE	DIFUSOR DEL AIRE
11	3007995			•		TAZZA	AIR DIFFUSER	DIFFUSEUR D'AIR	STAUSCHEIBE	DIFUSOR DEL AIRE
11	3008501				•	TAZZA	AIR DIFFUSER	DIFFUSEUR D'AIR	STAUSCHEIBE	DIFUSOR DEL AIRE
12	3007990	•				PROLUNGA GOMITO	ELBOW EXTENSION	PROLONGE COUDE	STAUSCHEIBEIBENHALTER	PROLONGACIÓN CODO
12	3007991		•			PROLUNGA GOMITO	ELBOW EXTENSION	PROLONGE COUDE	STAUSCHEIBEIBENHALTER	PROLONGACIÓN CODO
12	3007992			•	•	PROLUNGA GOMITO	ELBOW EXTENSION	PROLONGE COUDE	STAUSCHEIBEIBENHALTER	PROLONGACIÓN CODO
13	3007996	•				DISTRIBUTORE	DISTRIBUTOR	DISTRIBUTEUR	GASKOPF	DISTRIBUIDOR
13	3007997		•			DISTRIBUTORE	DISTRIBUTOR	DISTRIBUTEUR	GASKOPF	DISTRIBUIDOR
13	3007998			•		DISTRIBUTORE	DISTRIBUTOR	DISTRIBUTEUR	GASKOPF	DISTRIBUIDOR
13	3008503				•	DISTRIBUTORE	DISTRIBUTOR	DISTRIBUTEUR	GASKOPF	DISTRIBUIDOR
14	3007989	•	•	•	•	COLLEGAMENTO	CONNECTION	CABLE DE CONNEXION	MASSE-ANSCHLUßKABEL	CABLE CONEXIÓN
15	3007987	•				SONDA	PROBE	SONDE	IONISATIONSELEKTRODE	SONDA
15	3007988		•	•	•	SONDA	PROBE	SONDE	IONISATIONSELEKTRODE	SONDA
16	3008930	•				ELETTRODO	ELECTRODE	ELECTRODE	ZÜNDELEKTRODE	ELECTRODO
16	3008931		•	•		ELETTRODO	ELECTRODE	ELECTRODE	ZÜNDELEKTRODE	ELECTRODO
16	3008932			•		ELETTRODO	ELECTRODE	ELECTRODE	ZÜNDELEKTRODE	ELECTRODO
17	3008489	•	•			MOTORE	MOTOR	MOTEUR	MOTOR	MOTOR
17	3008492			•		MOTORE	MOTOR	MOTEUR	MOTOR	MOTOR
17	3008506				•	MOTORE	MOTOR	MOTEUR	MOTOR	MOTOR
18	3007454	•	•	•	•	PRESA (Motore)	SOCKET (Motor)	PRISE (Moteur)	STECKDOSE (Motor)	CONECTOR (Motor)
19	3007265	•	•	•	•	CAVALLOTTO	U BOLT	CAVALIER	BÜGELBOLZEN	SOPORTE FIJACIÓN
20	3007476	•	•			GIRANTE	FAN	TURBINE	GEBLÄSERAD	TURBINA
20	3007652			•		GIRANTE	FAN	TURBINE	GEBLÄSERAD	TURBINA
20	3008494				•	GIRANTE	FAN	TURBINE	GEBLÄSERAD	TURBINA
21	3007475	•	•			CONVOGLIATORE	SUCTION DUCT	CONVOYEUR D'AIR	LUFTLEITBLECH	GUÍA

N.	COD.	3761158	3761258	3761358	3761458	DESCRIZIONE	DESCRIPTION	DESCRIPTION	BESCHREIBUNG	DENOMINACIÓN
21	3007651			•		CONVOGLIATORE	SUCTION DUCT	CONVOYEUR D'AIR	LUFTLEITBLECH	GUÍA
21	3008552			•		CONVOGLIATORE	SUCTION DUCT	CONVOYEUR D'AIR	LUFTLEITBLECH	GUÍA
22	3005447	•	•	•	•	GRUPPO MISURAZIONE	TEST POINT	PRISE DE PRESSION	MESSNIPPEL	GRUPO TOMA DE PRESIÓN
23	3008003	•				ANELLO DI TENUTA	O-RING SEAL	JOINT D'ETANCHEITE	O-RING-DICHTUNG	JUNTA TÓRICA
23	3008004		•			ANELLO DI TENUTA	O-RING SEAL	JOINT D'ETANCHEITE	O-RING-DICHTUNG	JUNTA TÓRICA
23	3008005			•	•	ANELLO DI TENUTA	O-RING SEAL	JOINT D'ETANCHEITE	O-RING-DICHTUNG	JUNTA TÓRICA
24	3008009	•				IMBUTO FIAMMA	END CONE	EMBOUT GUEULARD	FLAMMROHR	TUBO LLAMA
24	3008010		•			IMBUTO FIAMMA	END CONE	EMBOUT GUEULARD	FLAMMROHR	TUBO LLAMA
24	3008011			•		IMBUTO FIAMMA	END CONE	EMBOUT GUEULARD	FLAMMROHR	TUBO LLAMA
24	3008498			•	•	IMBUTO FIAMMA	END CONE	EMBOUT GUEULARD	FLAMMROHR	TUBO LLAMA
25	3008006	•				MANICOTTO	MANIFOLD	MANCHON	FLAMMKOPF MIT GASANSCH.	COLLARÍN
25	3008007		•			MANICOTTO	MANIFOLD	MANCHON	FLAMMKOPF MIT GASANSCH.	COLLARÍN
25	3008008			•		MANICOTTO	MANIFOLD	MANCHON	FLAMMKOPF MIT GASANSCH.	COLLARÍN
25	3008502			•		MANICOTTO	MANIFOLD	MANCHON	FLAMMKOPF MIT GASANSCH.	COLLARÍN
26	3002698	•				SCHERMO	GASKET	JOINT ISOLANT	KESSELFLANSCH-DICHTUNG	JUNTA AISLANTE
26	3005795		•			SCHERMO	GASKET	JOINT ISOLANT	KESSELFLANSCH-DICHTUNG	JUNTA AISLANTE
26	3005813			•		SCHERMO	GASKET	JOINT ISOLANT	KESSELFLANSCH-DICHTUNG	JUNTA AISLANTE
26	3008500			•		SCHERMO	GASKET	JOINT ISOLANT	KESSELFLANSCH-DICHTUNG	JUNTA AISLANTE
27	3008013	•				FLANGIA MOBILE	MOVABLE FLANGE	BRIDE MOBILE	KESSELFLANSCH	BRIDA MOVIBLE
27	3008014		•			FLANGIA MOBILE	MOVABLE FLANGE	BRIDE MOBILE	KESSELFLANSCH	BRIDA MOVIBLE
27	3008015			•		FLANGIA MOBILE	MOVABLE FLANGE	BRIDE MOBILE	KESSELFLANSCH	BRIDA MOVIBLE
27	3008493			•		FLANGIA MOBILE	MOVABLE FLANGE	BRIDE MOBILE	KESSELFLANSCH	BRIDA MOVIBLE
28	3008937	•				REGOLATORE SERRANDA	AIR DAMPER REGULATOR	SYSTEME REGLAGE D'AIR	LUFTREGULIERUNG	REGULADOR REGISTRO AIRE
28	3008728		•			REGOLATORE SERRANDA	AIR DAMPER REGULATOR	SYSTEME REGLAGE D'AIR	LUFTREGULIERUNG	REGULADOR REGISTRO AIRE
28	3002395			•		REGOLATORE SERRANDA	AIR DAMPER REGULATOR	SYSTEME REGLAGE D'AIR	LUFTREGULIERUNG	REGULADOR REGISTRO AIRE
28	3007648			•		REGOLATORE SERRANDA	AIR DAMPER REGULATOR	SYSTEME REGLAGE D'AIR	LUFTREGULIERUNG	REGULADOR REGISTRO AIRE
29	3008815	•				SERRANDA ARIA	AIR DAMPER	VOLET D'AIR	LUFTKLAPPE	REGISTRO DEL AIRE
29	3008729		•			SERRANDA ARIA	AIR DAMPER	VOLET D'AIR	LUFTKLAPPE	REGISTRO DEL AIRE
29	3002394			•		SERRANDA ARIA	AIR DAMPER	VOLET D'AIR	LUFTKLAPPE	REGISTRO DEL AIRE
29	3008497			•		SERRANDA ARIA	AIR DAMPER	VOLET D'AIR	LUFTKLAPPE	REGISTRO DEL AIRE
30	3007479	•	•			CONDENSATORE 4µF	CAPACITOR 4 µF	CONDENSATEUR 4µF	KONDENSATOR 4µF	CONDENSADOR 4µF
30	3007655			•		CONDENSATORE 6,3 µF	CAPACITOR 6,3 µF	CONDENSATEUR 6,3 µF	KONDENSATOR 6,3 µF	CONDENSADOR 6,3 µF
30	3008499			•		CONDENSATORE 8 µF	CAPACITOR 8 µF	CONDENSATEUR 8 µF	KONDENSATOR 8 µF	CONDENSADOR 8 µF
32	3002316	•				PRESSOSTATO ARIA	AIR PRESSURE SWITCH	PRESSOSTAT AIR	LUFTDRUCKWÄCHTER	PRESÓSTATO AIRE
32	3007444		•	•	•	PRESSOSTATO ARIA	AIR PRESSURE SWITCH	PRESSOSTAT AIR	LUFTDRUCKWÄCHTER	PRESÓSTATO AIRE
33	3008017	•	•	•	•	RACCORDO E TUBETTO	CONNECTOR AND TUBE	MAMELON ET TUYAU	NIPPEL UND RÖHRCHEN	RACORD Y TUBO
34	3002558	•				GUARNIZIONE	SEAL	JOINT	DICHTUNG	JUNTA
34	3002559		•			GUARNIZIONE	SEAL	JOINT	DICHTUNG	JUNTA
34	3002560			•	•	GUARNIZIONE	SEAL	JOINT	DICHTUNG	JUNTA
35	3002967	•	•	•	•	APPARECCHIATURA MG569	CONTROL BOX MG569	BOITE DE CONTR. MG569	STEUERGERÄT MG569	CAJA DE CONTROL MG569
36	3008491	•	•	•	•	COLLEGAMENTO A.T.	HIGH VOLTAGE LEAD	CABLE HAUTE TENSION	KABEL ZÜNDELEKTRODEN	CABLES ELECTRODOS
37	3008490	•	•	•	•	COLLEGAMENTO SONDA	PROBE CONNECTION	CABLE DE CONNEXION	IONISATIONSKABEL	CABLE CONEXIÓN SONDA
38	3006937	•	•	•	•	SPINA 7 POLI	7 PIN PLUG	FICHE 7 POLES	7 - POLIGER STECKER	CONECT. MACHO DE 7 CONTAC
39	3002971	•	•	•	•	GRUPPO COLLEGAMENTI	ASSEMBLY CONNECTION	GROUPE DE CONNEXION	VERBINDUNGSSYSTEM	ENCHUFE CONECTORES