



AQUACIAT^{CALEO}™ TD

Heat pump



Compact and silent

Optimised for heating

High energy efficiency

Winter operation down to -20°C

Hot water production up to +65°C

Heating capacity : 26 to 101 kW



Heating



Hydraulic
module

HFC
407C



USE

The new generation of **AQUACIAT^{CALEO}™** heat pumps offers an optimal solution for all heating applications encountered in the Offices, Healthcare, Hotels, Administration, Shopping Centres and Collective Housing markets.

These units are designed for outdoor installation and require no special protection against adverse weather conditions.

The **AQUACIAT^{CALEO}™** uses outdoor air as the sole source of thermal energy for heating during the winter. Connected to high temperature static radiators, an underfloor heating system or comfort units, it produces hot water at +65°C at an outdoor temperature of -10°C which allows existing buildings to be heated with the greatest of ease.

Connected to a domestic hot water (DHW) production system with buffer tank capacity, the **AQUACIAT^{CALEO}™** allows for complete autonomy of the domestic hot water and conventional heating system, whilst guaranteeing comfort and considerable energy savings.

The **AQUACIAT^{CALEO}™** is optimised to use ozone-friendly HFC R407C refrigerant.

This range guarantees compliance with the most demanding requirements for increased seasonal energy efficiency (SCOP) and CO₂ reduction to comply with the various applicable European directives and regulations.

RANGE

AQUACIAT^{CALEO}™ TD series

Heating only version.

DESCRIPTION

AQUACIAT^{CALEO}™ units are packaged machines supplied as standard with the following components:

- Hermetic SCROLL compressors
- Water-cooled condenser, with brazed plates
- Air-cooled evaporator with axial fan motor assembly
 - copper tube coil, aluminium fins
- Electrical power and remote control cabinet:
 - 400V-3ph-50Hz (+/-10%) general power supply + Earth
 - transformer fitted as standard on the machine for supplying the remote control circuit with 24V
- Connect Touch electronic control module
- Hydraulic module with variable speed single pump
- Casing for outdoor installation

The entire AQUACIAT^{CALEO}™ range complies with the following EC directives and standards:

- Machinery directive 2006/42/EC
- Electromagnetic compatibility directive 2014/30/EC
- EMC immunity and emissions EN 61800-3 'C3'
- Low voltage directive 2014/35/EU
- RoHS 2011/65/EU
- Pressure equipment directive (PED) 2014/68/EU
- Machinery directive EN 60-204 -1
- Refrigerating systems and heat pumps EN 378-2

DESIGNATION

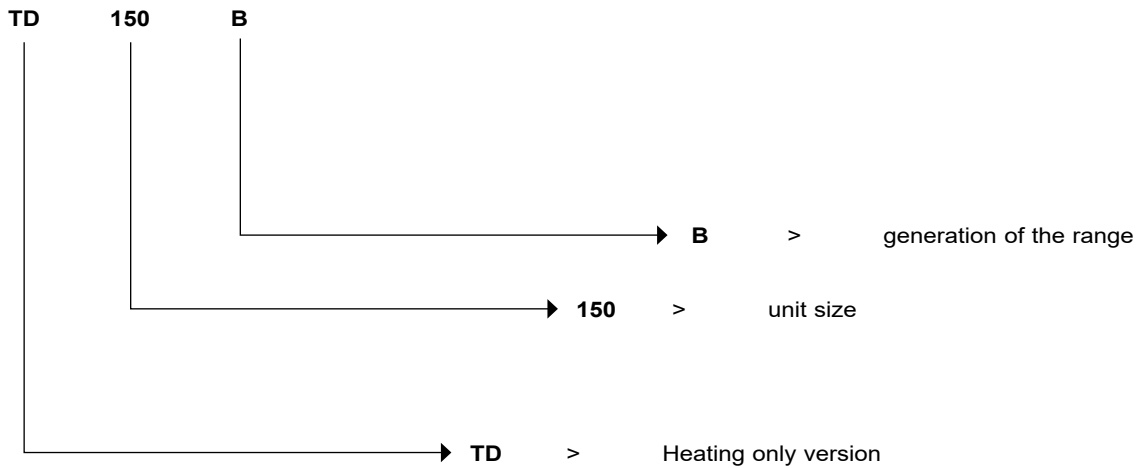

CONFIGURATION

TD	Standard
TD LN option	Standard Low Noise
TD XLN Option	Standard Xtra Low Noise

DESCRIPTION OF THE MAIN COMPONENTS

■ Compressors

- Hermetic SCROLL type
- Electronic motor overheating protection
- Crankcase heater
- Mounted on anti-vibration mounts

■ Water type heat exchanger

- Brazed-plate exchanger
- Plate patterns optimised for high efficiency
- 19 mm armafex thermal insulation
- Frost protection with heater

■ Air-cooled exchanger

- Coil made of grooved copper tubes with high-performance aluminium fins
- propeller fans with composite blades offering an optimised profile
- motors – IP 54, class F

■ Refrigerant accessories

- Dehumidifier filters
- Hygroscopic sight glasses
- Electronic expansion valves
- Service valves on the liquid line
- Four-way reverse cycle valve for defrosting

■ Regulation and safety instruments

- Low and high pressure sensors
- Safety valves on refrigerating circuit
- Water temperature control sensors
- Evaporator antifreeze protection sensor
- Factory-fitted evaporator water flow rate controller

■ Electrical cabinet

- Electrical cabinet with IP 44 protection rating
- A connection point without neutral
- Front-mounted main safety switch with handle
- Control circuit transformer
- 24V control circuit
- Fan and compressor motor circuit breaker
- Fan and compressor motor contactors
- Connect Touch microprocessor-controlled electronic control module
- Wire numbering
- Marking of the main electrical components

■ Frame

- Frame made from RAL7035 light grey & RAL 7024 graphite grey painted panels.

■ Connect Touch control module

- User interface with 4.3-inch touch screen
- Intuitive, user-friendly navigation using icons
- Clear text display of information available in 6 languages (F-GB-D-E-I-NL)



The electronic control module performs the following main functions:

- Regulation of the water temperature (at the return or at the outlet)
- Regulation of the water temperature based on the outdoor temperature (water law)
- Regulation for low temperature energy storage
- Second setpoint management
- Complete management of compressors with start-up sequence, timer and operating time balancing
- Self-regulating and proactive functions with adjustment of the control to counter parameter drift
- Optimised defrosting with free defrost function to optimise performance at partial load and the SCOP
- In-series staged power control system on the compressors according to the thermal requirements
- Management of compressor short cycle protection
- Frost protection (exchanger heaters)
- Phase reversal protection
- Management of occupied/unoccupied modes (according to the time schedule)
- Compressor and pump runtime balancing
- Management of the machine operation limit according to outdoor temperature
- Sound level reduction device (night mode according to the user programme) with limitation of compressor capacity and fan speed
- Diagnostics of fault and operating statuses
- Management of a fault memory allowing a log of the last 50 incidents to be accessed, with operating readings taken when the fault occurs
- Blackbox memory
- Master/slave management of the two machines in parallel with operating time balancing and automatic changeover if a fault occurs on one machine
- Weekly and hourly time schedule for the machine, including 16 periods of absence
- Pump standby based on demand (energy saving)
- Calculation of the water flow rate and operating pressure (hydraulic module version)
- Electronic adjustment of the water pump speed and water flow rate (variable-speed pump option)
- Display of all machine parameters (3 access levels, User/Maintenance/Factory, password-protected): temperature, setpoints, pressures, water flow rate (hydraulic version), runtime.
- Display of trend curves for the main values
- Storage of maintenance manual, wiring diagram and spare parts list.

AVAILABLE OPTIONS

■ Remote management

Connect Touch is equipped as standard with an RS485 port and an ETHERNET (IP) connection, offering a range of options for remote management, monitoring and diagnostics. Using the integrated Webservice, a simple internet connection uses the unit's IP address to access the Connect Touch interface on the PC, facilitating everyday management tasks and maintenance operations.

A range of communication protocols are available: MODBUS/JBUS RTU (RS485) or TC/IP as standard, LONWORKS – BACNET IP (certified BTL) as an option, enabling most CMS/BMS to be integrated.

Several contacts are available as standard, enabling the machine to be controlled remotely by wired link:

- Automatic operation control: when this contact is open, the machine stops
- Setpoint 1/setpoint 2 selector: when this contact is closed, a second Heating setpoint is activated (unoccupied mode, for example)
- Fault reporting: fault reporting: this contact indicates the presence of a major fault which has caused the machine to stop
- Domestic hot water demand
- On/off control for a boiler
- 4-stage on/off management for additional heaters.

Contacts available as an option:

- Setpoint adjustable via 4-20 mA signal: used to adjust the setpoint

■ Maintenance

Connect Touch has two maintenance reminder functions as standard, making users aware of the need to regularly perform maintenance operations and to guarantee the service life and performance of the unit. These two functions can be activated independently.

A reminder message appears on the unit's HMI screen, and stays there until it is acknowledged by the maintenance operator. The information and alert relating to these functions are available on the communication bus to be used on the CMS/BMS.

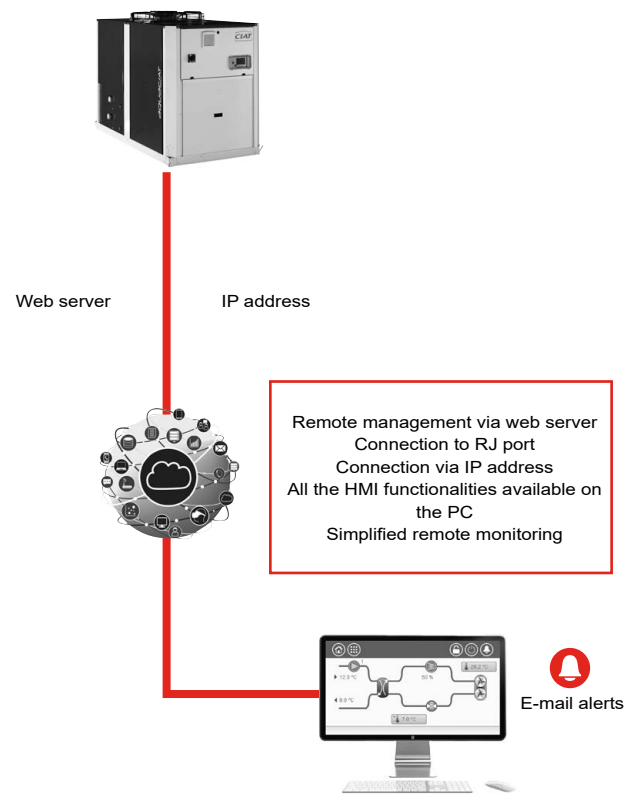

- the scheduled maintenance reminder: when activated, this function enables the period between two maintenance inspections to be set. This period may be set by the operator in either days, months or operating hours, depending on the application.
- the compulsory F-GAS sealing test maintenance reminder: when activated, this function, which is the default factory setting, enables the period between two sealing tests to be selected, according to the refrigerant charge, in compliance with the FGAS regulations

AVAILABLE OPTIONS

Options	Description	Avantages	TD
Corrosion protection, traditional coils	Fins made of pre-treated aluminium (polyurethane and epoxy)	Improved corrosion resistance, recommended for moderate marine and urban environments	•
XtraFan	Fans with 100 Pa maximum available pressure. Each fan equipped with a connection flange & sleeves allowing the connection to the ducting system.	Ducted fan discharge, optimised temperature control, based on the operating conditions and system characteristics	TD 100 to 300
Low Noise	Aesthetic and sound absorbing compressor enclosure	Noise level reduction by 1 to 2 dB(A)	•
Xtra Low Noise	Acoustic compressor enclosure and low-speed fans	Noise emission reduction at reduced fan speed	TD 100 to 300
Soft Starter	Electronic starter on each compressor	Reduced start-up current	•
Hydraulic module frost protection	Electric heater on the hydraulic module	hydraulic module frost protection at low outside temperatures down to -20°C	•
Master/slave operation	Unit equipped with supplementary water outlet temperature sensor kit to be field-installed allowing master/slave operation of two units connected in parallel	Optimised operation of two units connected in parallel operation with operating time equalisation	•
LON gateway	Two-directional communication board complying with Lon Talk protocol	Connects the unit by communication bus to a building management system	•
Bacnet over IP	Two-directional high-speed communication using BACnet protocol over Ethernet network (IP)	Easy and high-speed connection by Ethernet line to a building management system. Allows access to multiple unit parameters	•
Compliance with Russian regulations	EAC certification	Compliance with Russian regulations	•
Condenser screw connection sleeves kit	Condenser inlet/outlet screw connection sleeves	Allows unit connection to a screw connector	•
M2M supervision (accessory)	Monitoring solution which allows customers to track and monitor their equipment remotely in real time	Real-time expert technical support to improve equipment availability and reports at customer hand to monitor and optimize operating equipment.	•
Anti-vibration mounts	Elastomer antivibratils mounts to be place under the unit (Material classified B2 fire class according to DIN 4102).	Isolate unit from the building, avoid transmission of vibration and associate noise to the buiding. Must be used in conjunction with a flexible connection on the water side	•
Condenser flexible sleeves connection	Flexibles connections on the condenser water side	Easy to install. Limits the transmission of vibrations to the water network	•
Set point adjustment by 4-20mA signal	Connections enabling a 4-20 mA signal input	Simplified energy management, enabling the setpoint to be set by a 4-20 mA external signal	•
Plastic tarp	Plastic sheeting covering the units, with strapping securing it on the wooden pallet.	Allow unit to avoid dust and dirt from the outside environment during stocking and shipping.	•

• ALL MODELS

Refer to the selection tool to find out which options are not compatible.

TECHNICAL CHARACTERISTICS

AQUACIAT ^{CALEO™} TD			80	100	120	150	200	300	
Heating									
Standard unit Full load performances*									
HA1	Nominal capacity	kW	25,9	32,3	43,4	51,5	64,7	102,0	
	COP	kW/kW	4,02	4,04	4,27	4,32	3,97	4,24	
HA2	Nominal capacity	kW	25,5	32,0	43,0	51,6	66,6	102,0	
	COP	kW/kW	3,37	3,35	3,56	3,64	3,42	3,58	
HA3	Nominal capacity	kW	25,0	31,6	42,7	52,2	67,9	102,0	
	COP	kW/kW	2,91	2,89	3,10	3,16	3,00	3,12	
HA4	Nominal capacity	kW	24,6	31,3	42,6	53,3	68,0	103,0	
	COP	kW/kW	2,43	2,42	2,60	2,66	2,52	2,64	
Standard unit Seasonal energy efficiency**									
HA1	SCOP _{30/35°C}	kW/kW	3,33	3,44	3,58	3,66	3,57	3,62	
	η _s heat _{30/35°C}	%	130	135	140	143	140	142	
	P _{rated}	kW	19,2	32,8	44,5	55,9	74,1	108,7	
HA3	SCOP_{47/55°C}	kW/kW	2,93	2,94	3,10	3,15	3,00	3,16	
	η_s heat_{47/55°C}	%	114	115	121	123	117	123	
	P _{rated}	kW	19	31	43	54	63	94	
Energy labelling			A+	A+	A+	A+	A+	-	
Operating weight⁽¹⁾									
Unit + hydraulic module option			kg	418	435	555	579	919	1039
Sound levels									
Standard unit									
Sound power ⁽²⁾			dB(A)	78	83	82	84	84	85
Sound pressure at 10m ⁽³⁾			dB(A)	46	51	51	53	52	53
Unit + Low Noise option									
Sound power ⁽²⁾			dB(A)	76	80	80	80	82	82
Sound pressure at 10m ⁽³⁾			dB(A)	44	49	48	49	50	51
Unit + Xtra Low Noise option									
Sound power ⁽²⁾			dB(A)	NA	76	76	77	79	79
Sound pressure at 10m ⁽³⁾			dB(A)	NA	45	45	45	47	47
Dimensions									
Length			mm	1110		1114		2273	
Depth			mm	1327		2100		2100	
Height			mm	1440		1440		1440	
Compressor				Hermetic Scroll 48.3 r/s					
Quantity				1	1	1	1	2	2
Number of power stages				1	1	1	1	2	2

* In accordance with standard EN14511-3:2018.

** In accordance with standard EN14825:2018, average climate.

HA1 Heating mode conditions: Water heat exchanger water entering/leaving temperature 30°C/35°C, outside air temperature tdb/twb = 7°C db/6°C wb, evaporator fouling factor 0 m2. k/W

HA2 Heating mode conditions: Water heat exchanger water entering/leaving temperature 40°C/45°C, outside air temperature tdb/twb = 7°C db/6°C wb, evaporator fouling factor 0 m2. k/W

HA3 Heating mode conditions: Water heat exchanger water entering/leaving temperature 47°C/55°C, outside air temperature tdb/twb = 7°C db/6°C wb, evaporator fouling factor 0 m2. k/W

HA4 Heating mode conditions: Water heat exchanger water entering/leaving temperature 55°C/65°C, outside air temperature tdb/twb = 7°C db/6°C wb, evaporator fouling factor 0 m2. k/W

η_s heat_{30/35°C} & SCOP_{30/35°C}
 η_s heat_{47/55°C} & SCOP_{47/55°C}
 - Values calculated in accordance with EN 14825:2018
 Values in bold comply with Ecodesign Regulation (EU) No. 813/2018 for heating application
 - Not applicable

(1) Weight given as a guide. Please refer to the unit nameplate.

(2) In dB ref=10-12 W, 'A' weighted. Declared dual-number noise emission values in accordance with ISO 4871 with an associated uncertainty of +/-2dB(A). Measured in accordance with ISO 9614-1 and certified by Eurovent.

(3) In dB ref 20 μPa, 'A' weighted. Declared dual-number noise emission values in accordance with ISO 4871 with an associated uncertainty of +/-2dB(A). For information, calculated from the sound power Lw(A).



Eurovent certified values

TECHNICAL CHARACTERISTICS

AQUACIAT ^{CALEO™} TD		80	100	120	150	200	300
Refrigerant		R407C PRG = 1800 following AR4					
Charge	kg	8,8	9,7	10	13,2	22	26,5
	tCO ₂ eq	15,6	17,2	17,7	23,4	39,0	47,0
Oil							
Charge	l	4,1	4,1	4,1	4,1	8,2	8,2
Control		Connect Touch					
Minimum capacity	%	100	100	100	100	50	50
Condenser		Direct expansion, plate heat exchanger					
Water volume	l	6,4	8,2	9,6	12,1	16,4	22,7
Max. water-side operating pressure with hydraulic module	kPa	400	400	400	400	400	400
Fan		Axial with rotating impeller.					
Quantity	1	1	1	1	2	2	2
Total air flow (high speed)	l/s	3748	3736	4035	4036	7479	8072
Standard rotation speed	r/s	12	12	12	12	12	12
Rotation speed with Xtrafan	r/s	-	16	16	16	16	16
Evaporator		Grooved copper tube and aluminium fins					
Hydraulic module							
Variable speed pump		Pump. victaulic screen filter. valve. purge valves (water and air). cavitation pressure sensor					
Water connections		Victaulic					
Connections	inch	1" 1/4	1" 1/2	1" 1/2	1" 1/2	2"	2"
External diameter	mm	42,4	48,3	48,3	48,3	60,3	60,3
Chassis paint colour		Colour code RAL 7035 and RAL7024					

ELECTRICAL SPECIFICATIONS

AQUACIAT ^{CALEO™} TD		80	100	120	150	200	300
Power circuit							
Nominal voltage	V-ph-Hz	400-3-50					
Voltage range	V	360-440					
Control circuit supply							
24 V via internal transformer							
Maximum start-up current (Un)⁽¹⁾							
Standard unit	A	102	130	172	203	158	243
Unit with soft starter option	A	54	69	92	103	97	144
Unit power factor at maximum capacity⁽²⁾							
0,82 0,83 0,87 0,87 0,83 0,87							
Max. operating input power⁽²⁾							
kW 12 16 21 25 32 48							
Nominal unit current draw⁽³⁾							
A 16 20 25 30 42 57							
Maximum unit current draw (Un)⁽⁴⁾							
A 21 27 35 41 56 79							
Max. current draw (Un-10%)⁽⁵⁾							
A 22 29 38 45 60 86							

- (1) Maximum instantaneous starting current (maximum operating current of the smallest compressor + fan current + locked rotor current of the largest compressor).
 (2) Input power, compressors + fans, at the unit operating limits (saturated suction temperature: 10°C, saturated condensing temperature: 65°C) and nominal voltage of 400 V (data given on the unit nameplate).
 (3) Standardised EUROVENT conditions: condenser entering/leaving water temperature = 40/45°C, outside air temperature db/wb = 7°C/6°C.
 (4) Maximum unit operating current at maximum unit input power and 400 V (values given on the unit's nameplate).
 (5) Maximum unit operating current at maximum unit input power and 360 V.

■ Short circuit current withstand capability (TN system⁽¹⁾)

AQUACIAT ^{CALEO™} TD - Standard unit (disconnect switch)		80	100	120	150	200	300
Value without upstream protection							
Short time (1s) assigned current (I _{cw})	kA rms	0,6	0,6	1,26	1,26	1,26	2
Allowable peak assigned current (I _{pk})	kA pk	4,5	4,5	6	6	6	10
value with upstream protection by circuit breaker							
Conditional short circuit assigned current (I _{cc})	kA rms	7	7	7,7	7,7	6,1	10
Circuit breaker - Compact range type		40	40	50	63	80	100
Reference number ⁽²⁾		5SY6340-7	5SY6340-7	5SY4350-7	5SY4363-8	5SP4380-7	5SP4391-7
Value with upstream protection by fuses							
Conditional short circuit assigned current (I _{cc})	kA rms	50	50	50	50	14,5	22
Fuse (gL/gG)		40	40	63	63	80	125

- (1) Type of system earthing
 (2) If another current limitation protection system is used, its time-current and thermal constraints (I²t) trip characteristics must be at least equivalent to those of the recommended circuit breaker.
 The short circuit current stability values given above are for the TN system.

Electrical data and operating conditions notes:

- TD 080-300 units have a single power connection point located immediately upstream of the main disconnect switch.
- The control box includes the following standard features:
 - a main disconnect switch,
 - starter and motor protection devices for each compressor, the fans and the pump,
 - the control devices.
- Field connections:
 All connections to the system and the electrical installations must be in full accordance with all applicable local codes.
- The Aquaciat Caléo TD units are designed and built to ensure conformance with these codes. The recommendations of European standard EN 60204-1 (machine safety - electrical machine components - part 1: general regulations - corresponds to IEC 60204-1) are specifically taken into account, when designing the electrical equipment.

NOTES:

- Generally the recommendations of IEC 60364 are accepted as compliance with the requirements of the installation directives. Conformance with EN 60204-1 is the best means of ensuring compliance with the Machines Directive § 1.5.1.
- Annex B of EN 60204-1 describes the electrical characteristics used for the operation of the machines.

- The operating environment for the TD units is specified below:

- Environment⁽¹⁾ - Environment as classified in EN 60721 (corresponds to IEC 60721):
 - outdoor installation⁽¹⁾
 - ambient temperature range: -20°C to +40°C, class 4K4H
 - altitude: ≤ 2000 m
 - presence of hard solids, class 4S2 (no significant dust present)
 - presence of corrosive and polluting substances, class 4C2 (negligible)
- Power supply frequency variation: ± 2 Hz.
- The neutral (N) conductor must not be connected directly to the unit (if necessary use a transformer).
- Overcurrent protection of the power supply conductors is not provided with the unit.
- The factory-installed disconnect switch is of a type suitable for power interruption in accordance with EN 60947.
- The units are designed for connection to TN networks (IEC 60364). Units delivered with speed drive (options 116) are not compatible with IT network due to speed drive.

Caution: If particular aspects of an actual installation do not conform to the conditions described above, or if there are other conditions which should be considered, always contact your local CIAT representative.

- (1) The required protection level for this class is IP43BW (according to reference document IEC 60529). All TD units are protected to IP44CW and fulfil this protection condition.

DIMENSIONS

■ AQUACIAT^{CALEO}™ TD 80 to 100

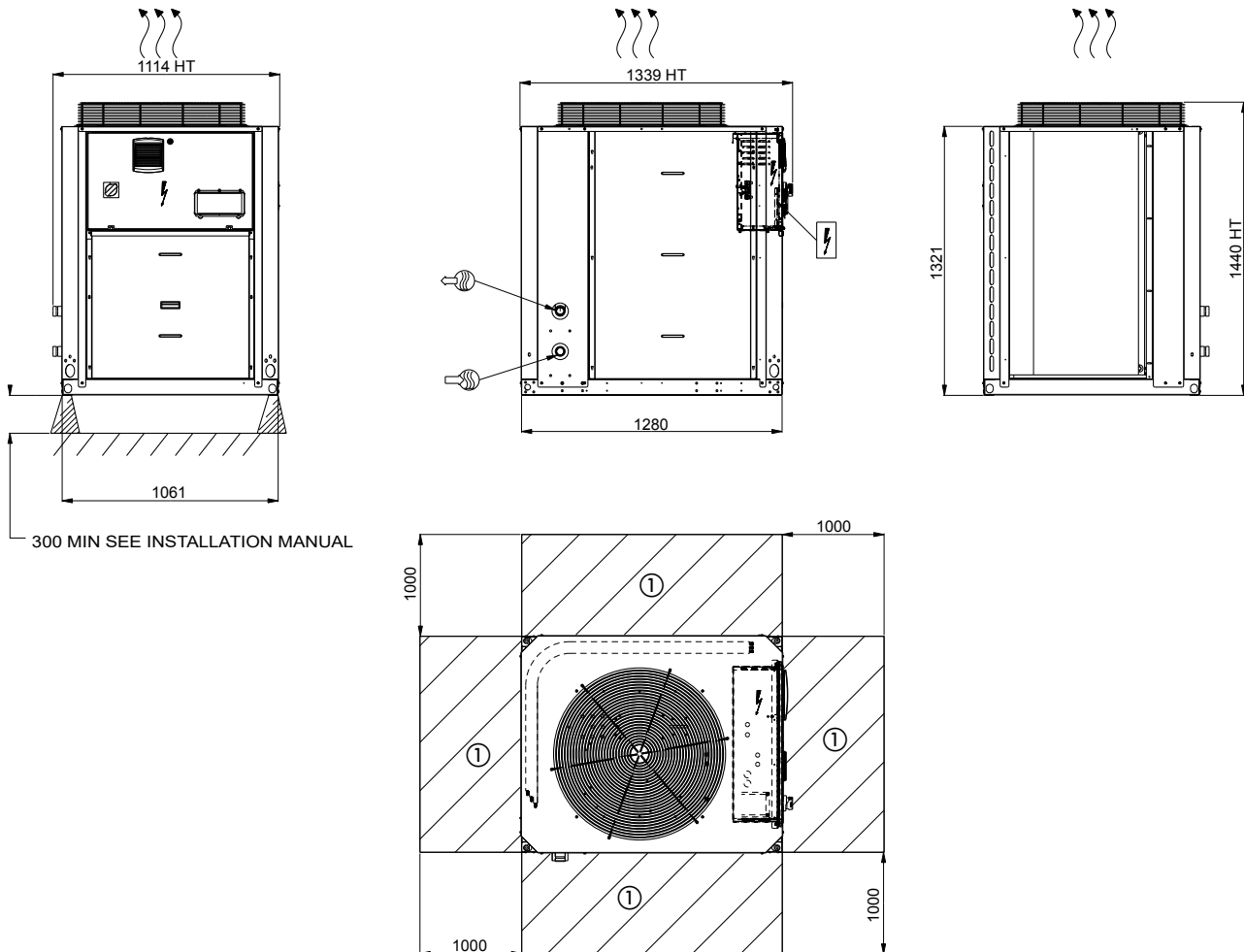

Key

Dimensions en mm

- ① Clearance required for maintenance and air flow
- Water inlet
- Water outlet
- Air outlet, do not obstruct
- Electrical cabinet

NOTES :

Non-contractual drawings.

When designing a system, refer to the certified dimensional drawings provided with the unit or available on request.

Please refer to the certified dimensional drawings for the positioning of the fixing points, weight distribution points and centre of gravity coordinates.

DIMENSIONS

■ AQUACIAT^{CALEO}™ TD 120 to 150

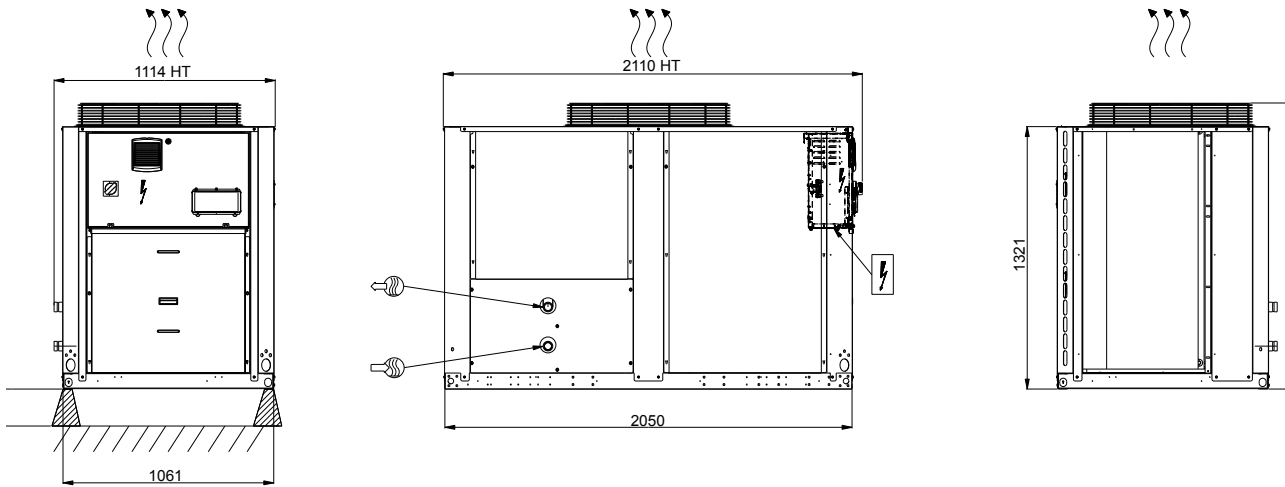

300 MIN SEE INSTALLATION MANUAL

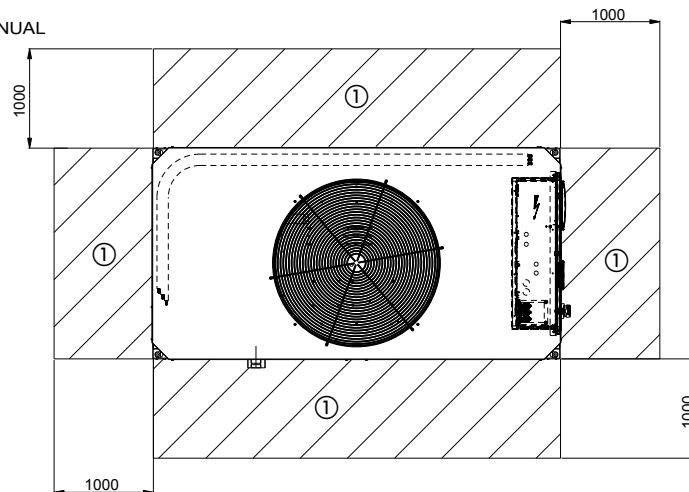

Key

Dimensions en mm

- ① Clearance required for maintenance and air flow
- Water inlet
- Water outlet
- Air outlet, do not obstruct
- Electrical cabinet

NOTES :

Non-contractual drawings.

When designing a system, refer to the certified dimensional drawings provided with the unit or available on request.

Please refer to the certified dimensional drawings for the positioning of the fixing points, weight distribution points and centre of gravity coordinates.

DIMENSIONS

■ AQUACIAT^{CALEO™} TD 200 to 300

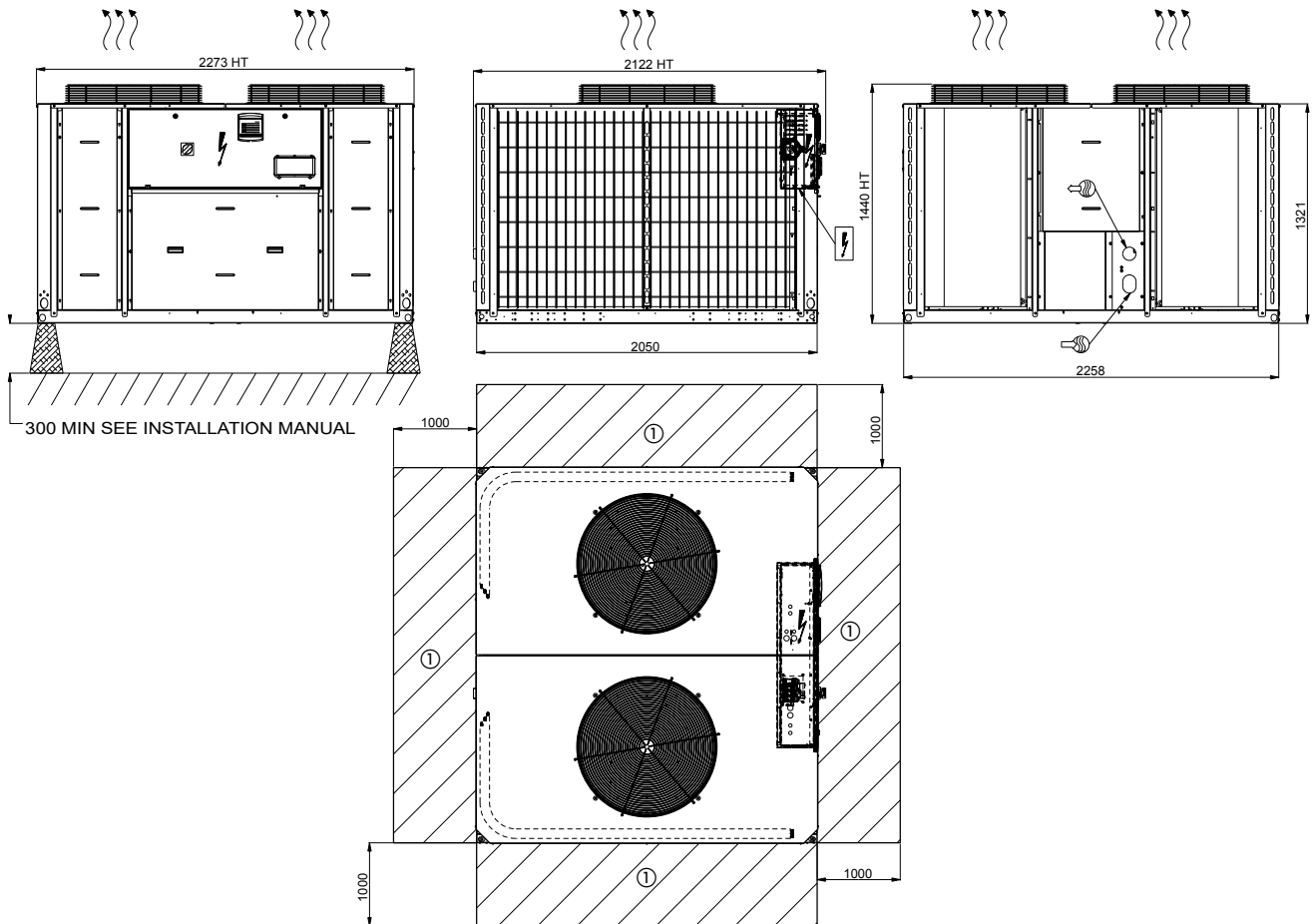
Key

Dimensions en mm

① Clearance required for maintenance and air flow

Water inlet

Water outlet

Air outlet, do not obstruct

Electrical cabinet

NOTES :
Non-contractual drawings.
When designing a system, refer to the certified dimensional drawings provided with the unit or available on request.
Please refer to the certified dimensional drawings for the positioning of the fixing points, weight distribution points and centre of gravity coordinates..

DIMENSIONS

■ AQUACIAT^{CALEO}™ TD 100 XTRA fan option

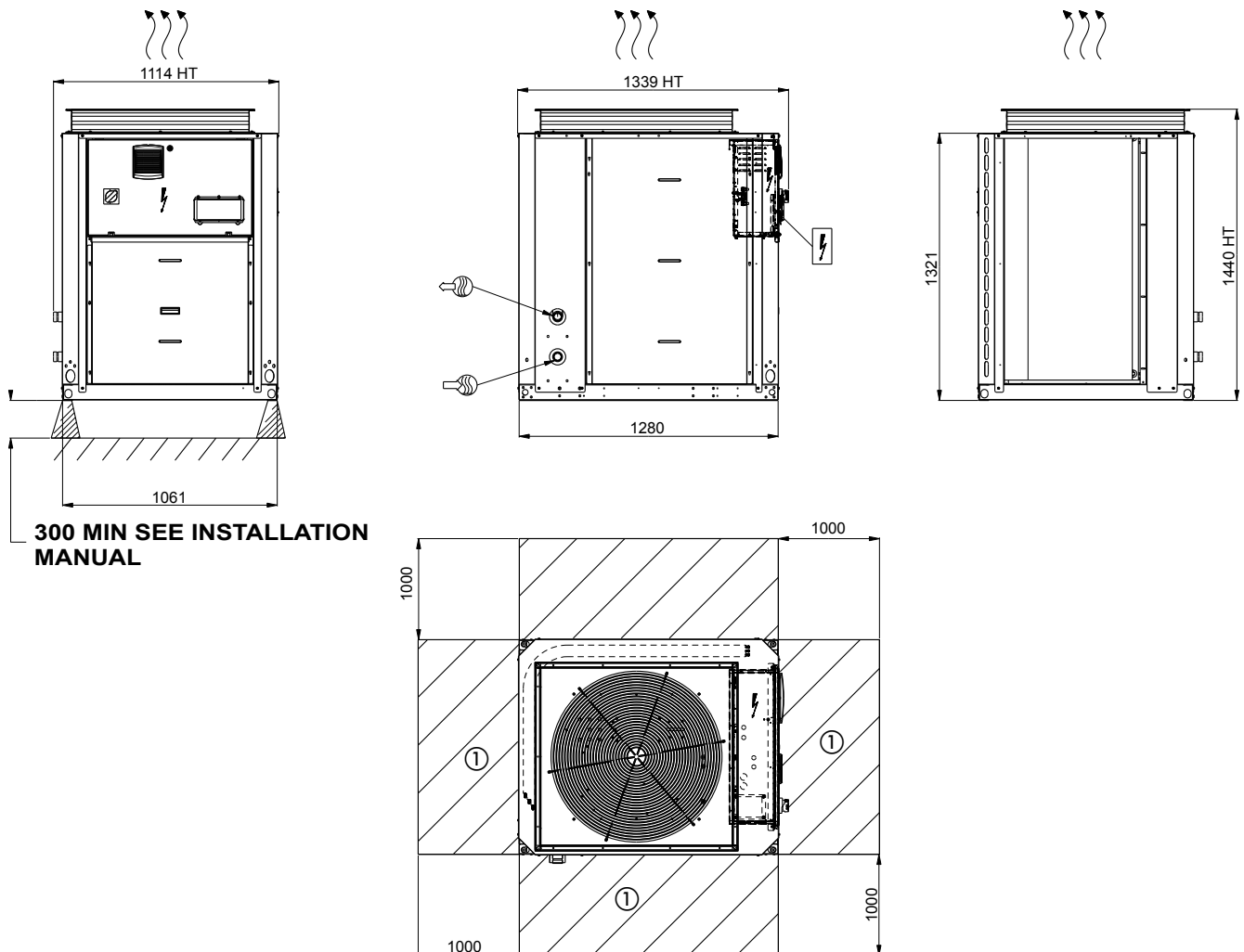

300 MIN SEE INSTALLATION MANUAL

Key

Dimensions en mm

- ① Clearance required for maintenance and air flow
- ↻ Water inlet
- ↻ Water outlet
-))) Air outlet, do not obstruct
- ⚡ Electrical cabinet

NOTES :

Non-contractual drawings.

When designing a system, refer to the certified dimensional drawings provided with the unit or available on request.

Please refer to the certified dimensional drawings for the positioning of the fixing points, weight distribution points and centre of gravity coordinates.

DIMENSIONS

■ AQUACIAT^{CALEO}™ TD 120 - 150 XTRA fan option

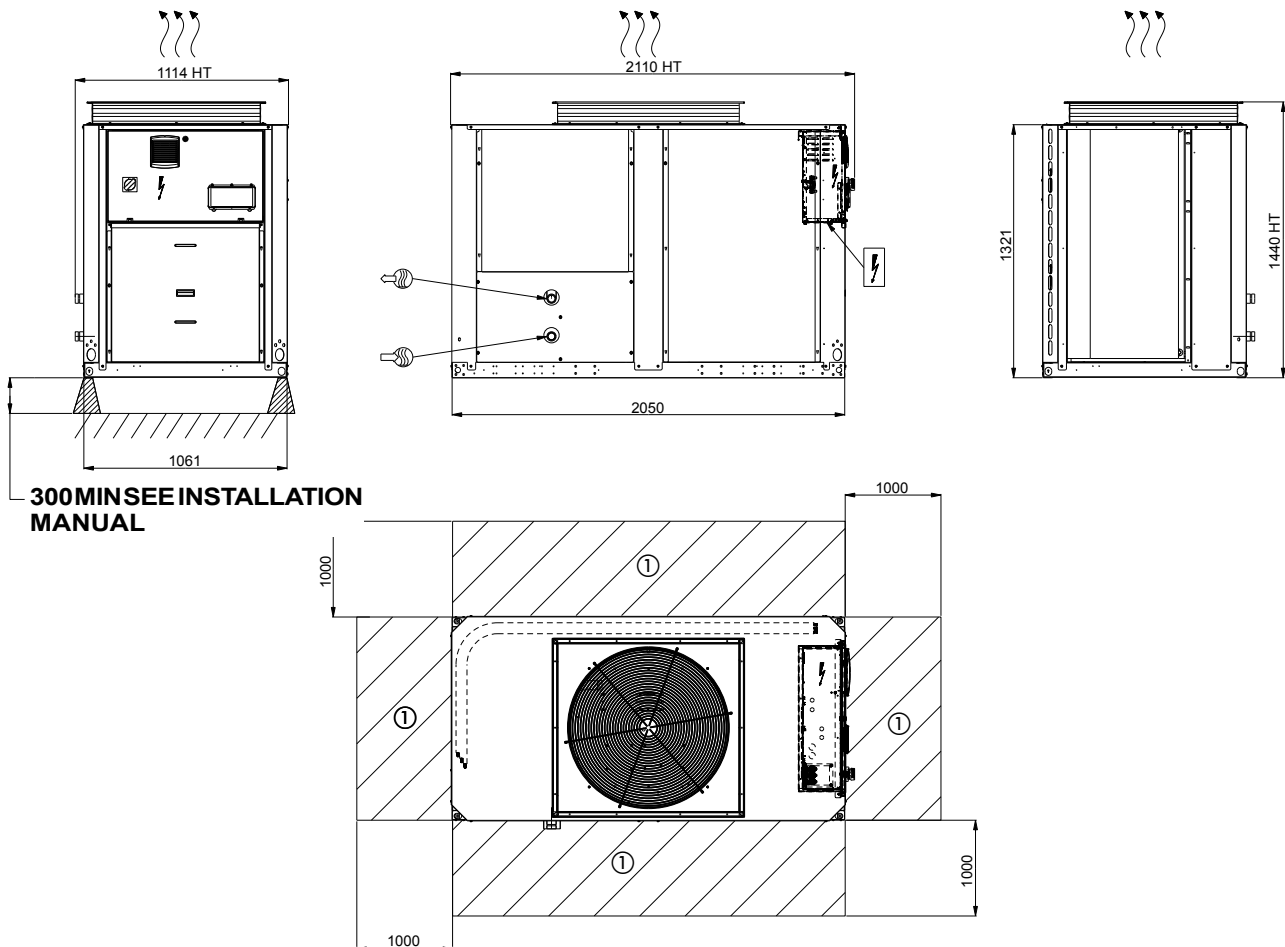

300MINSEE INSTALLATION
MANUAL

Key

Dimensions en mm

- ① Clearance required for maintenance and air flow
- Water inlet
- Water outlet
- Air outlet, do not obstruct
- Electrical cabinet

NOTES :

Non-contractual drawings.

When designing a system, refer to the certified dimensional drawings provided with the unit or available on request.

Please refer to the certified dimensional drawings for the positioning of the fixing points, weight distribution points and centre of gravity coordinates.

DIMENSIONS

■ AQUACIAT^{CALEO}™ TD 200 - 300 XTRA fan option

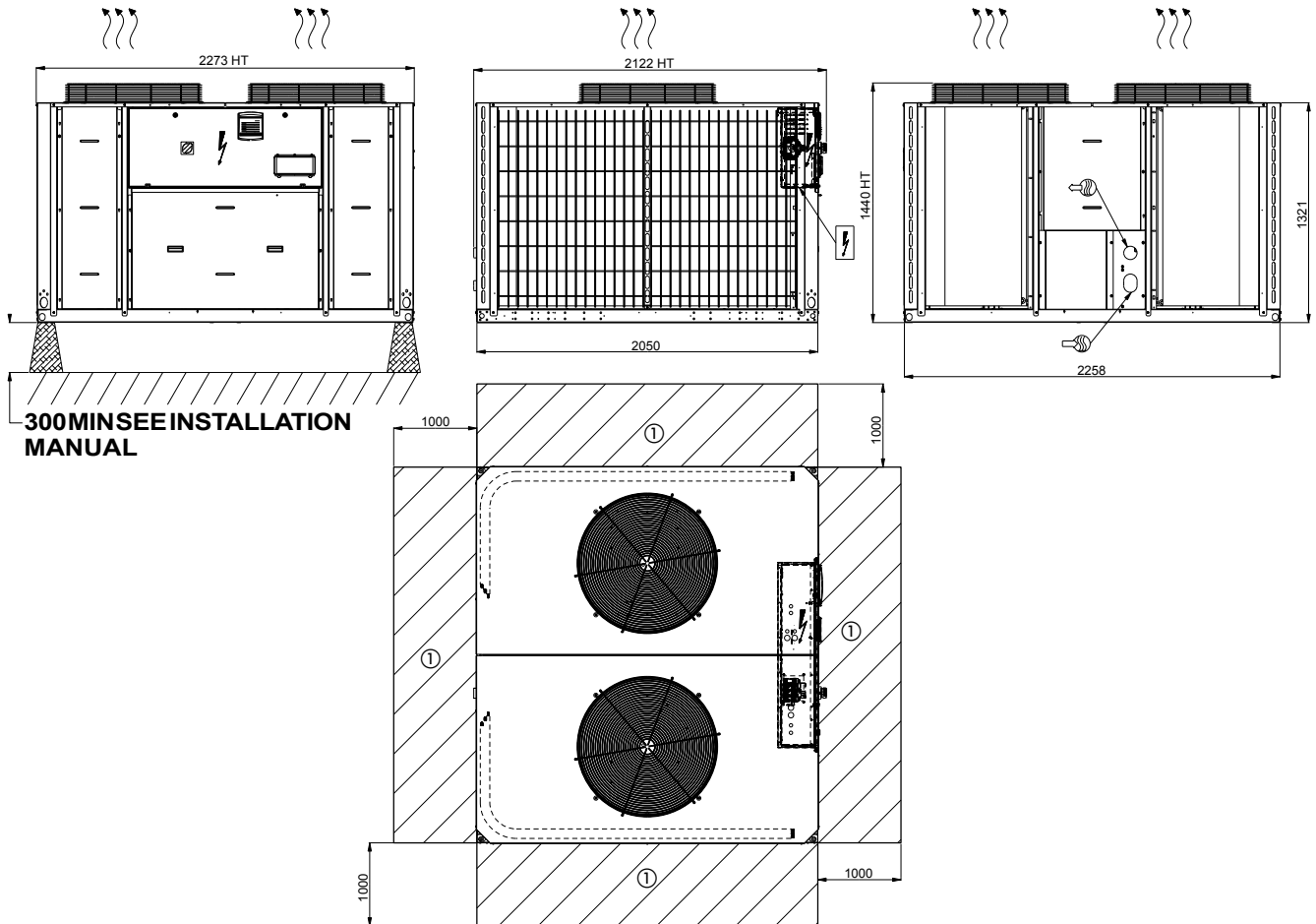
Key

Dimensions en mm

- ① Clearance required for maintenance and air flow
- ↖ Water inlet
- ↗ Water outlet
-))) Air outlet, do not obstruct
- ⚡ Electrical cabinet

NOTES :
Non-contractual drawings.
When designing a system, refer to the certified dimensional drawings provided with the unit or available on request.
Please refer to the certified dimensional drawings for the positioning of the fixing points, weight distribution points and centre of gravity coordinates.