



FLOWAY

Air handling unit

*Plug & Play AHU with onboard control,
Energy class A+ across the entire range, High
efficiency heat recovery unit, EC fan motor
assembly, high performance*



Specifications	Class
Mechanical strength	D2
Airtightness	L1
Filter bypass leak	F9
Thermal transmission	T3
Thermal bridge	TB2

Air flow rate: 500 to 18,000 m³/h

USE

The **FLOWAY** dual-flow air handling unit is a **PLUG & PLAY** ventilation unit equipped with a highly efficient heat recovery unit with plug fans and high performance EC motors, designed to meet all the requirements of recent ecodesign regulations.

Unit supplied ready to use, prewired, preprogrammed in the factory and supplied with a remote control.

It draws clean, fresh air indoors using, on average, 80% less energy than that needed for air conditioning (cooling and heating).

The Floway AHU range is particularly well-suited to the following applications:

- Administrative buildings, Offices
 - Shopping Centres
 - Education facilities, Libraries, Community centres
 - Nursing homes, Healthcare facilities
 - Cafés, Hotels, Restaurants
 - Collective housing
- All facilities where ventilation is required.

High energy-efficiency heat recovery unit

Two types of high efficiency heat recovery units are available based on the CTA Floway model:

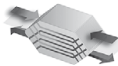

"CONTRA FLOW" plate heat exchanger with bypass (Classic PHE & Vertical PHE models)



Rotary heat exchanger (Classic RHE-RHEZ and Access RHE models)
Year-round optimal heat recovery
Classic RHEZ: With purge sector as standard

AIR FLOW RANGE

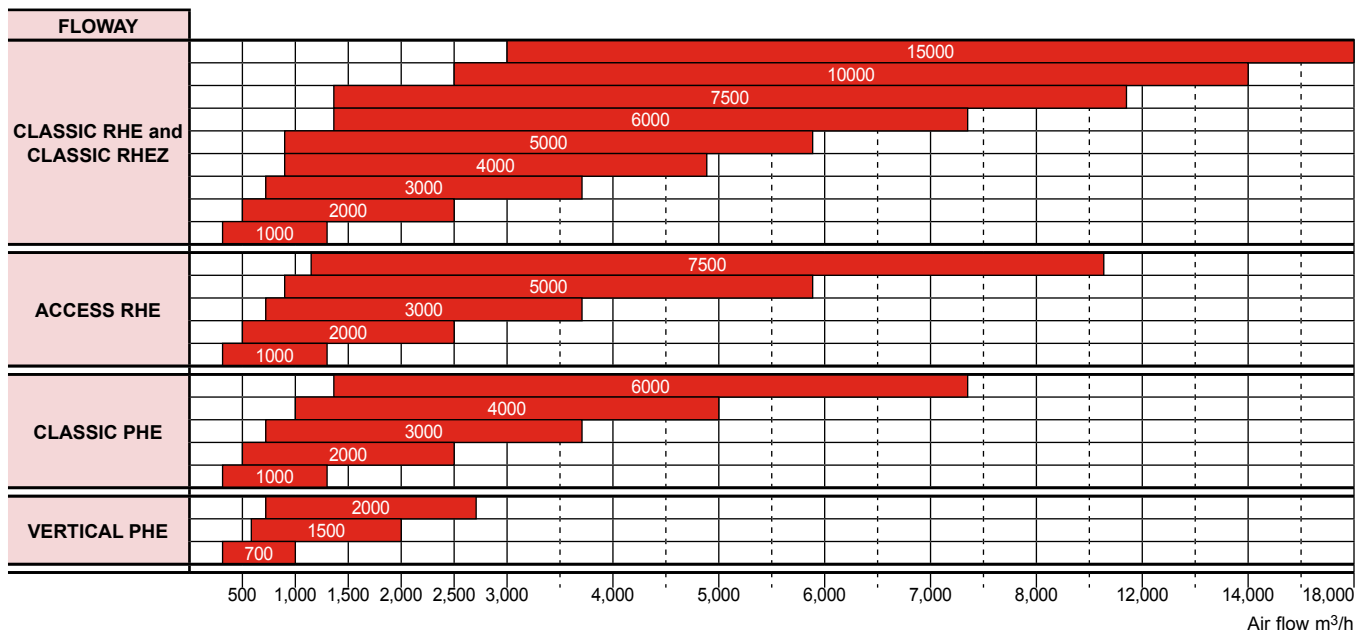

DESCRIPTION

Casing

- Double-skin panels made from steel sheet metal, galvanised on both sides, thickness 0.8 mm.
- External panels made from galvanised steel, precoated in RAL7035.
- M0/A1 insulation fire rating.
- Mineral wool, thickness 50 mm.

Filtration

- M5, F7, F9 filters.
- Filter cells kept compressed by a special system to ensure a leaktight seal.
- Classic PHE & RHE-RHEZ, Vertical PHE models: fouling value monitored by analogue sensor and displayed by controller.
- Access RHE model: pressure switch control on each air flow. Pressure switch status displayed by controller.

Ventilation

- "Plug Fan" type direct-drive fan.
- Plug fan driven by an electronically commutated motor with built-in speed control.

Heat recovery units

- "Contra Flow" plate heat exchanger equipped with a motorised bypass (Vertical PHE and Classic PHE models). Efficiency greater than 80% across the range of air flows.
- Rotary heat exchanger equipped with rotation speed control (Classic RHE model). Efficiency greater than 80% at nominal flow rate.
- Purge sector as standard (Classic RHEZ model)
- Constant speed rotary heat exchanger (Access RHE model). 80% efficiency at nominal flow rate.

Hydraulic coil

- Copper pipes, aluminium fins.
- Coil can be integrated or additional (cased).
- With the accessories fitted: 2- or 3-way control valve and 0-10 V actuator controlled by FLOWAY Control for precise setpoint maintenance.
- Stainless steel condensate drain pan (cooling coil or mixed coil only).

Electric heaters

- High-limit safety thermostats with automatic and manual reset.
- 2- or 3-stage control based on the selected option, controlled by the FLOWAY Control.

DX coil

- Copper tubes, aluminium fins.
 - For reversible heating/cooling operation.
 - Internal space optimised for VRV units.
 - Condensate drain pan in stainless steel.
- List of outdoor units optimised for Floway Access available on request.

Electrics box

- Electrics box for power, control and regulation built into the unit, comprising as standard:
 - Power supply (3-Ph/400 V/Earth or 1-Ph/230 V/Earth).
 - Main disconnect switch.
 - Protected transformer.
 - Protection and control of all electrical components by a circuit breaker.
 - Peripheral options and power terminal block.
 - Factory-programmed PLC control.
 - Hand-held cabled micro-terminal.
 - Fault summary contact.
 - 3 temperature sensors.
 - 4 pressure sensors (2 pressure sensors and 2 pressure switches on the Access model).

Accessories

- Damper formed of airfoil blades, powered by a TOR servomotor with spring return.
- Flexible sleeve.
- Adjustable feet.
- CO₂ air quality sensor.
- Roof.
- Canopy.
- Mixing section (Classic RHE model).

POWER SUPPLY

FLOWAY CLASSIC PHE and CLASSIC RHE-RHEZ			
Size	Nominal flow rate (m ³ /h)	Rated current (A)	Supply type
1000	1000	5,8	1~230 V - 50 Hz 3~400 V - 50 Hz
2000	2000	4,2	
3000	3000	7,0	
4000	4000	8,6	
5000	5000	8,6	
6000	6000	10,0	
7500	7500	10,0	
10000	10000	19,0	
15000	15000	24,6	
FLOWAY ACCESS RHE			
Size	Nominal flow rate (m ³ /h)	Rated current (A)	Supply type
1000	1000	5,4	1~230 V - 50 Hz 3~400 V - 50 Hz
2000	2000	2,9	
3000	3000	6,1	
5000	5000	8,8	
7500	7500	10,3	
FLOWAY VERTICAL PHE			
Size	Nominal flow rate (m ³ /h)	Rated current (A)	Supply type
700	1000	6,2	1~230 V - 50 Hz
1500	1500	4,2	3~400 V - 50 Hz
2000	2000	4,2	

CONTROL

FLOWAY Control

FLOWAY features, as standard, an electrics box equipped with a factory-programmed PLC and a wired human machine interface.

Available control features CLASSIC PHE - CLASSIC RHE - ACCESS RHE - VERTICAL PHE models		Included	Option
Timer	Option to define up to 6 weekly programs and 6 annual programs. The programs available are: temperature and ventilation in eco/comfort mode, shut-down, night cooling and frost protection	X	
Human Machine Interface	LCD display	X	
	Colour touch screen		X
	Webserver (integrated web pages)		X
	Room remote control with special interface for the end user		X
Remote actuation and CMS	Communication Protocols	MODBUS RS485 (RTU)	X
		MODBUS IP	
		BACnet IP	
		KNX	
		LON	
Filtration	Monitoring filter fouling (via analogue sensor or pressure switch depending on the model)	X	
Ventilation management	Single zone	Constant air volume	X
		Variable air volume via the CO ₂ sensor	
	Multi-zone	Constant supply air pressure (for installations equipped with ducted variable flow louvres)	
Temperature management	Control of return air or supply air temperature	X	
	Room temperature control		X
	Automatic correction of the set-point based on the outdoor temperature	X	
	Free-cooling	X	
Direct expansion coil**	Gradual action on a reversible inverter outdoor unit		X
	Hot/cold control		X
	Optimised defrost cycle management		X
Heat recovery unit anti-icing	Via fresh air temperature control	X	
	Via ΔP control on the exhaust air		X
	Via electric pre-heater		X
Protection of the internal components	Checking the heat protection for the motors	X	
	Checking the temperature and pressure sensors	X	
	Alarm if the operating limit thresholds are exceeded	X	
Auxiliary contacts	Inputs (dry contacts)	Fire fault	X
		Coil 1* pump fault	X
		Coil 2* pump fault	X
		Remote On/Off	X
		Eco/Comfort changeover	X
	Outputs (dry contacts)	AHU operating feedback	X
		Maintenance fault summary*	X
		Danger fault summary	X
		Configurable external heater or cooler*	X
		On/Off coil pump no. 1*	X
On/Off coil pump no. 2*	X		

* Not available on the Access RHE model

** Not available on the Classic PHE, Classic RHE-RHEZ, Vertical PHE models

AIR FLOW DIMENSIONS AND ORIENTATION

FLOWAY CLASSIC PHE, CLASSIC RHE-RHEZ, ACCESS RHE

SIZES	FLOWAY Classic PHE, Classic RHE-RHEZ, Access RHE									
	Height (C) (mm)	Width (B) (mm)	Length (A) (mm)				Weight (kg)*			
			Classic PHE	Classic RHE	Classic RHEZ	Access RHE	Classic PHE	Classic RHE	Classic RHEZ	Access RHE
1000	958	810	1580	1266	1480	1266**	200	201	273	180
2000	1158	1010	1150 + 800	510 + 800	800+800	1310**	350	309	382	250
3000	1359	1210	1264 + 800	800 + 800	1264+800	1600	465	432	556	330
4000	1659	1510	1264 + 800	800 + 800	1264+800	-	580	558	654	-
5000	1659	1510	-	800 + 800	1264+800	1600	-	604	704	445
6000	1959	1810	1407 + 800	800 + 800	1407+850	-	765	702	742	-
7500	1959	1810	-	800 + 800	1407+850	1600	-	751	811	580
10000	2090	1920	-	1100 + 1100	1820+1100	-	-	955	1065	-
15000	2340	2192	-	1100 + 1200	1820+1200	-	-	1250	1357	-

* Without internal option.

** Circular coupling; protrudes 47 mm on either side.

Condensate draining connection diameter: 16 mm smooth

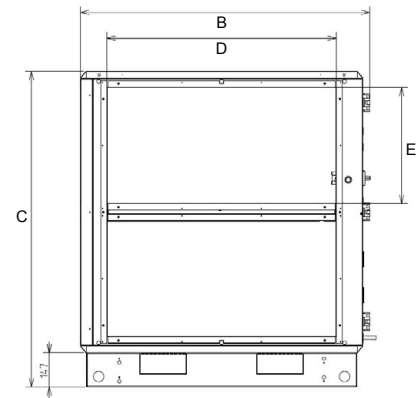
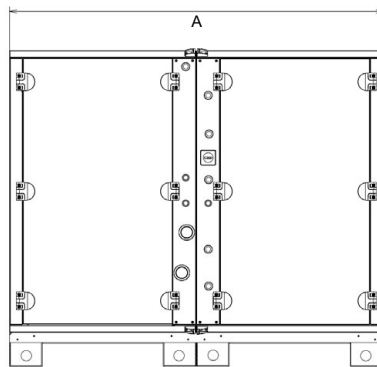

AIR FLOW ORIENTATION

Access RHE and Classic RHE-RHEZ models

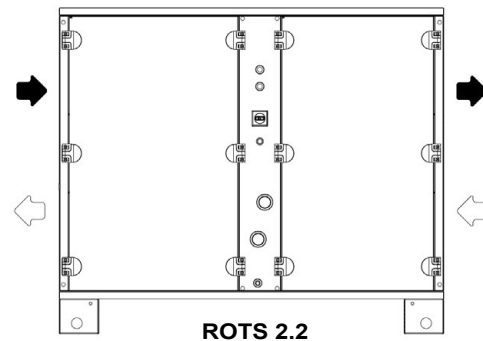
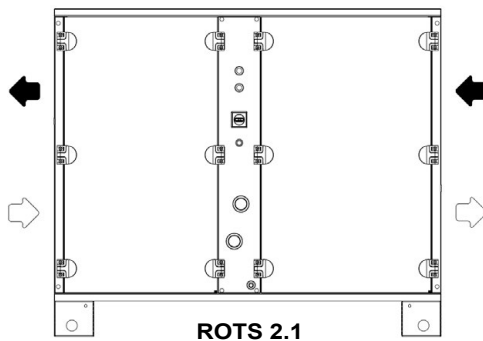

WHITE ARROW = FRESH AIR
 BLACK ARROW = EXTRACTED AIR

Classic PHE models

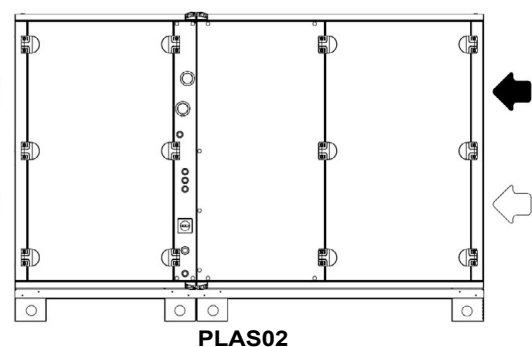
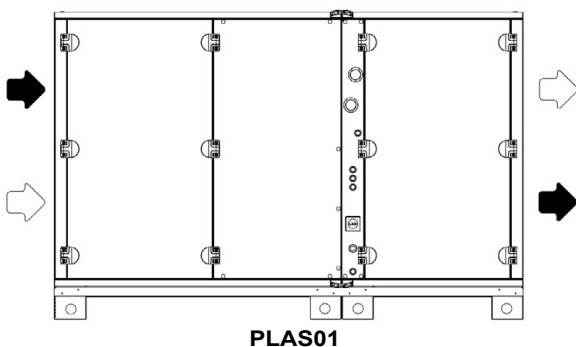

FLOWAY Vertical PHE

MODELS	Dimensions			Weight (kg)*
	Height	Length	Width	
700	1385	1313	730	202
1500	1758	1593	832	330
2000	1901	1735	832	389

Condensate draining connection diameter: 16 mm smooth.
* Without internal option

Size 700

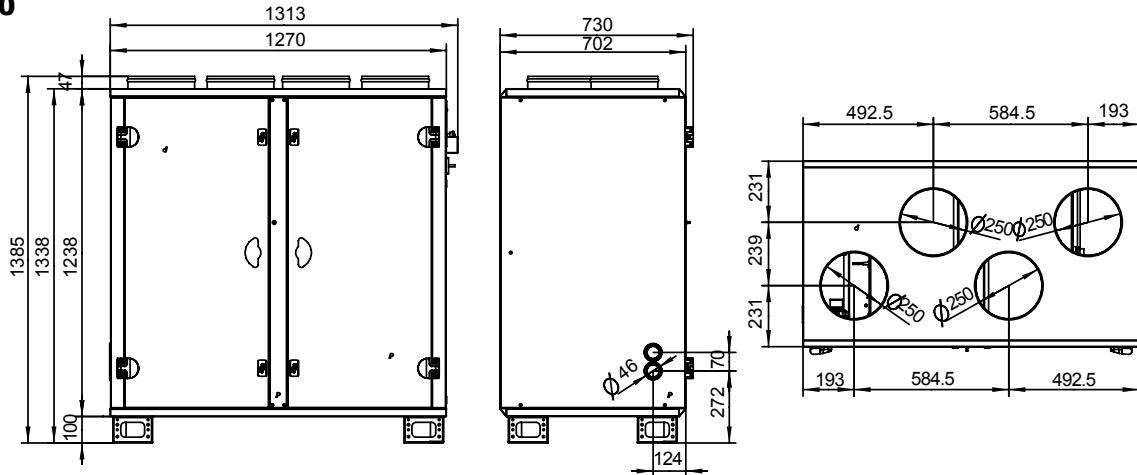

Size 1500

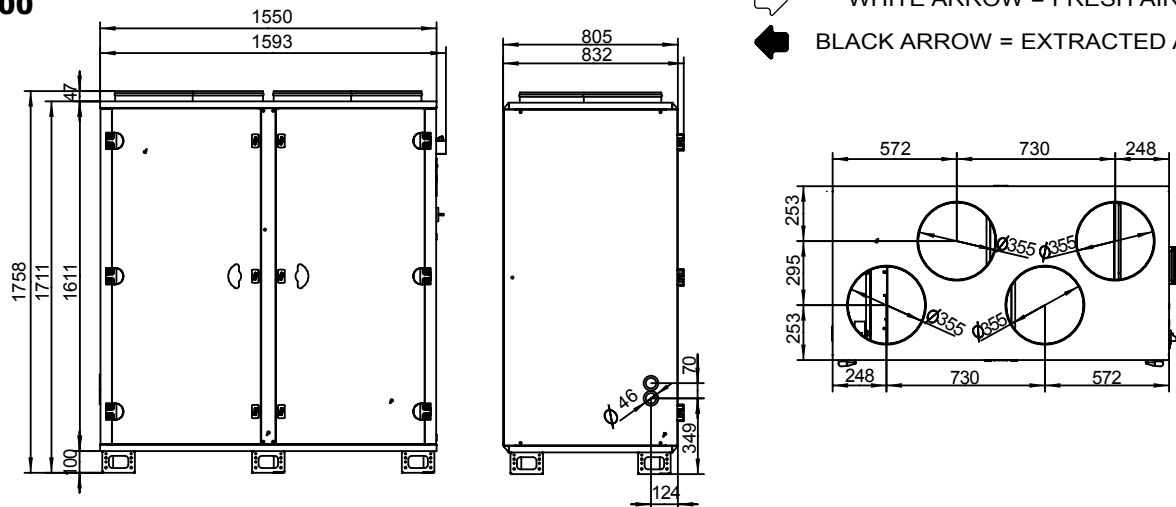

WHITE ARROW = FRESH AIR
 BLACK ARROW = EXTRACTED AIR

Size 2000

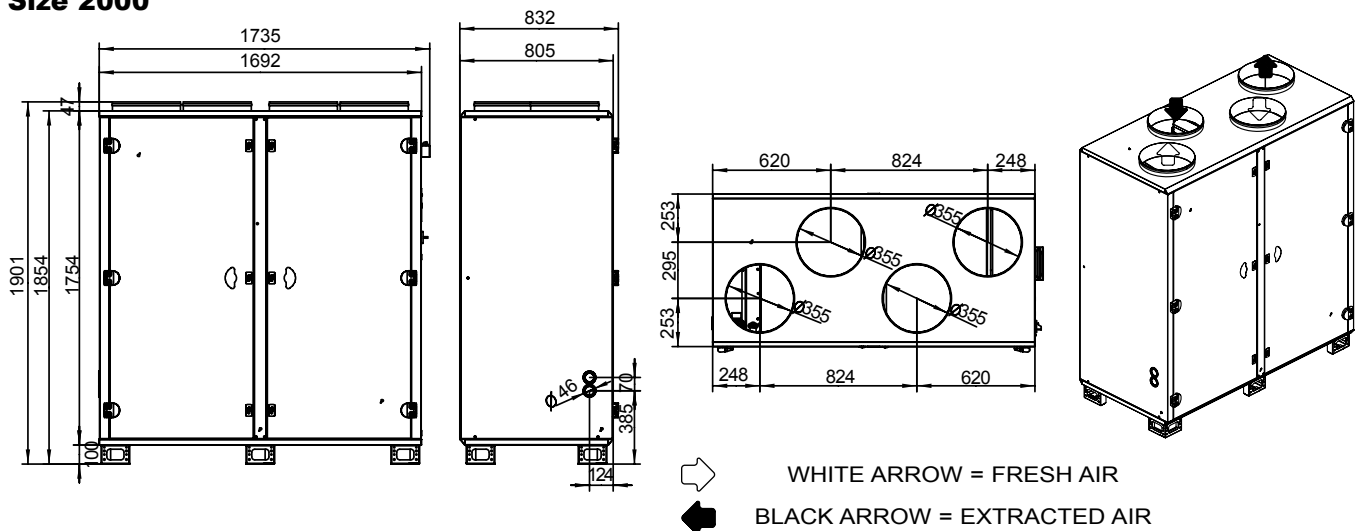

WHITE ARROW = FRESH AIR
 BLACK ARROW = EXTRACTED AIR

Additional casing (MUST ONLY BE POSITIONED IN A HORIZONTAL AIR FLOW)

Size of additional casing	Corresponding Floway model	Width (A) (mm)	Height (B) (mm)	Length (C) (mm)	Weight +/-10% (kg)
1	Classic RHE-RHEZ & PHE 1000 Vertical PHE 700	810	589	400	49
2	Classic RHE-RHEZ & PHE 2000 Vertical PHE 1500 & 2000	1010	689	400	62
3	Classic RHE-RHEZ & PHE 3000	1210	759	400	68
4	Classic RHE-RHEZ & PHE 4000 - 5000	1510	909	400	88
5	Classic RHE-RHEZ & PHE 6000 - 7500	1810	1059	400	112

