

Catalogo ricambi  
Catalogue pièces détachées  
Spare parts catalogue  
Ersatzteilkatalog  
Onderdelenlijst  
Catálogo de recambios

# RIELLO

**Caldiae Murali**  
**Chaudières murales**  
**Wall hung boilers**  
**Wandgastherme**  
**Gaswandkessel**  
**Calderas mural a gas**

**COD.**

**MOD.**

**TYP.**

**20190064**

**CONDEXA HPR 35**

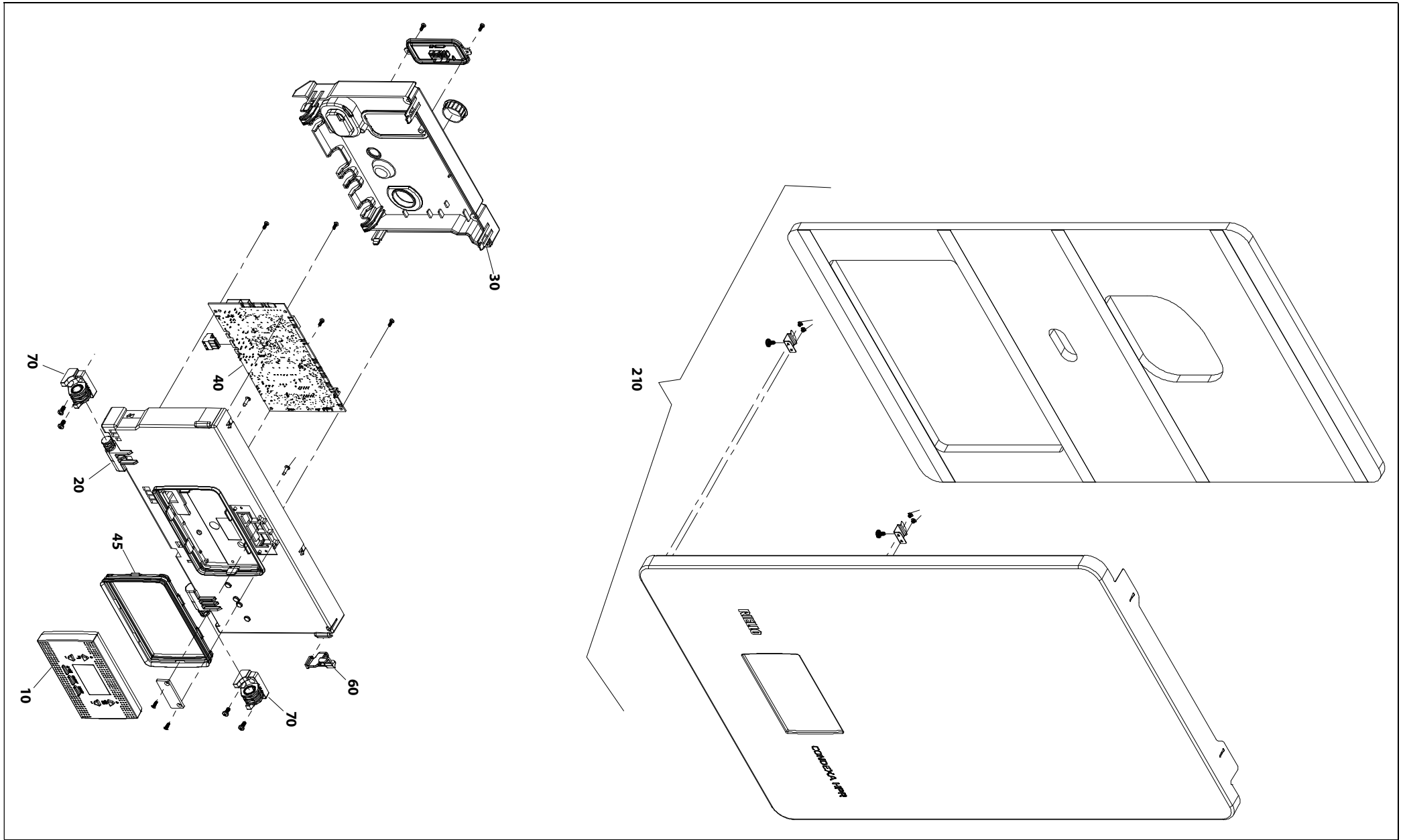

N.	COD.	RC 20190064	DESCRIZIONE	DESCRIPTION	DESCRIPTION	BESCHREIBUNG	BESCHRIJVING	DESCRIPCIÓN
10	20200198	•	Pannello comandi	Tableau de commande	Control panel	Verkleidung Steuerungen	Bedieningspaneel	Panel mandos
20	4R109975	•	Cruscotto	Tableau de bord	Instrument panel	Instrumentenbrett	Dashboard	Panel display
30	20198522	•	Copertura	Capot	Cover	Abdeckung	Kap	Tapa (cubierta)
40	20198523	•	Scheda gestione	Carte de gestion	Management PCB	Verwaltungskarte	Beheerkaart	Tarjeta de gestión
45	4R105461	•	Guarnizione	Joint	Seal	Dichtung	Afdichting	Junta
60	4R105513	•	Gancio	Crochet	Hook	Haken	Klem	Gancho
70	4R105512	•	Cerniera	Charniere	Hinge	Scharniereinheit	Scharnier	Cable señal PWM
210	20198448	•	Mantello	Jupe	Shell	Mantel	Mantel	Panel

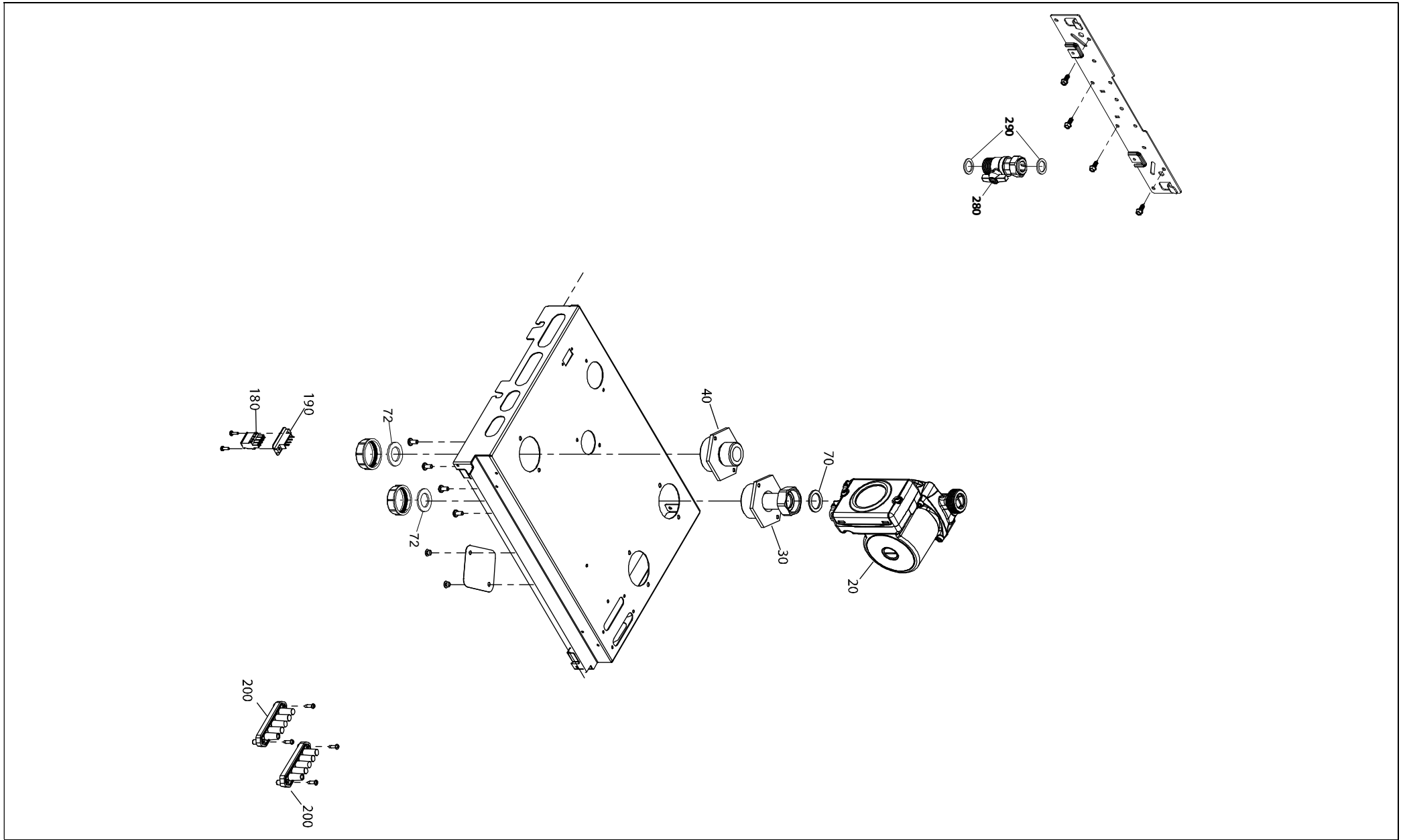

N.	COD.	RC 20190064	DESCRIZIONE	DESCRIPTION	DESCRIPTION	BESCHREIBUNG	BESCHRIJVING	DESCRIPCIÓN
20	20198567	•	Circolatore	Circulateur	Circulator	Umlaufpumpe	Circulatiepomp	Circulador
30	20198545	•	Rampa	Tuyau	Pipe	Strecke	Buisje	Rampa
40	20198566	•	Nipple	Mamelon	Nipple	Nippel	Nippels	Manguito
70	4363781	•	Guarnizione	Joint	Seal	Dichtung	Afdichting	Junta
72	20198543	•	Guarnizione	Joint	Seal	Dichtung	Afdichting	Junta
180	4R107480	•	Connettore	Raccord	Connector	Steckverbinder	Aansluiting	Conector
190	4R109838	•	Connettore	Raccord	Connector	Steckverbinder	Aansluiting	Conector
200	4R105529	•	Passacavo	Passe cable	Cable grommet	Kabeldurchführung	Kabeldoorvoer	Pasacables
280	4R108891	•	Rubinetto gas	Robinet gaz	Gas cock	Gashahn	Gaskraan	Llave de gas
290	4363389	•	Guarnizione	Joint	Seal	Dichtung	Afdichting	Junta

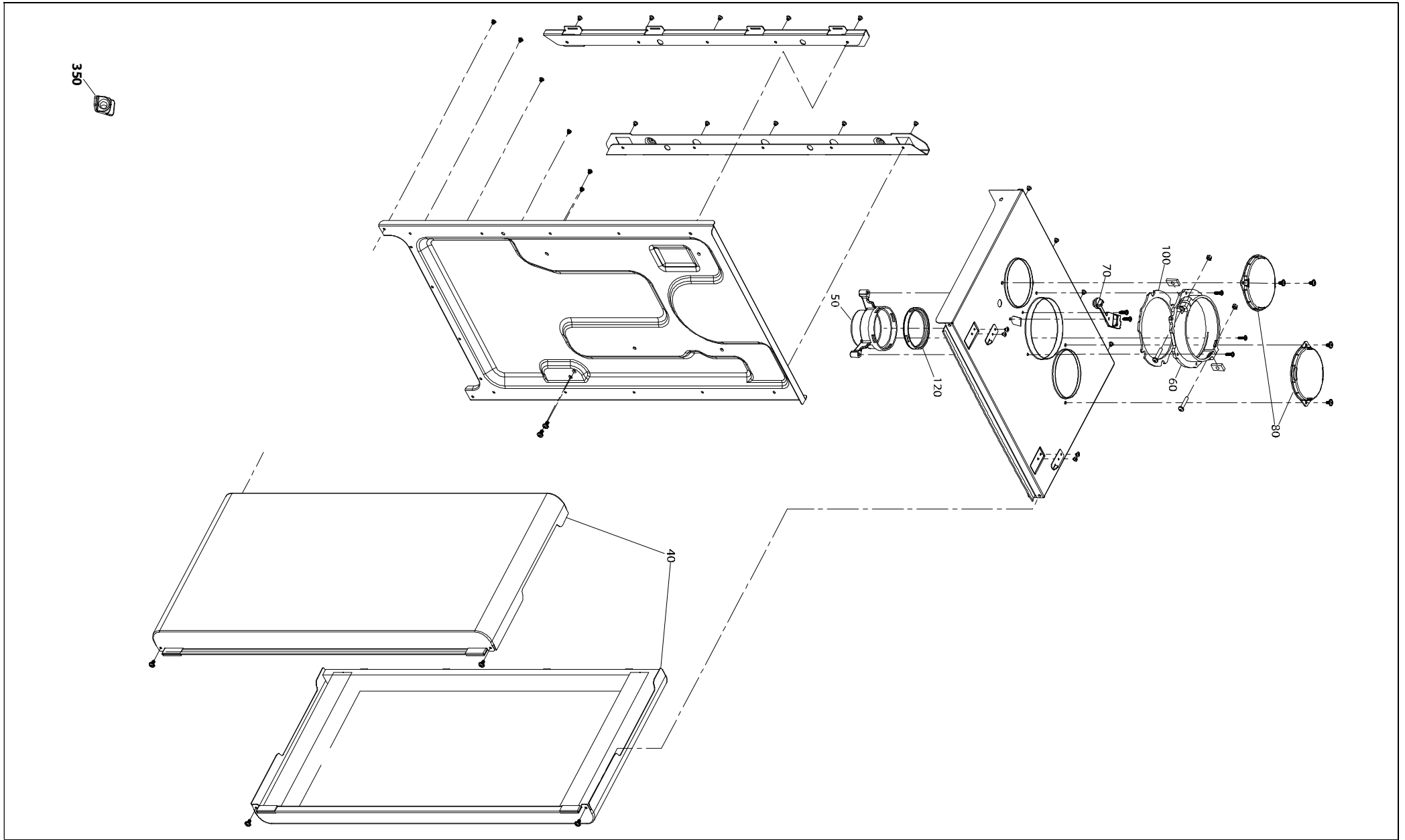

N.	COD.	RC 20190064	DESCRIZIONE	DESCRIPTION	DESCRIPTION	BESCHREIBUNG	BESCHRIJVING	DESCRIPCIÓN
40	4R105709	●	Pannello laterale	Panneau latéral	Lateral panel	Seitenpaneel	Zijpaneel	Panel lateral
50	4365881	●	Torretta scarico fumi	Conduit des gaz brûlés	Flue gas exhaust turret	Rauchablassturm	Rookafvoertoren	Torreta evacuación de humos
60	4R107474	●	Flangia fumi	Bride fumée	Flue gas flange	Rauchgasflansch	Rookflens	Brida humos
70	4R107476	●	Tappo presa analisi fumi	Bouchon prise analyse fumées	Flue gas analysis plug	Verschluss für Abgasmessöffnung	Stekkers Smoke analyse	Tapón toma de análisis de humos
80	4366888	●	Tappo	Bouchon	Plug	Verschluss	Dop	Tapón
100	4R107475	●	Guarnizione flangia	Joint bride	Flange seal	Flanschdichtung	Flensafdichting	Junta brida
120	4365889	●	Guarnizione	Joint	Seal	Dichtung	Afdichting	Junta
350	4R108419	●	Tappo	Bouchon	Plug	Verschluss	Dop	Tapón

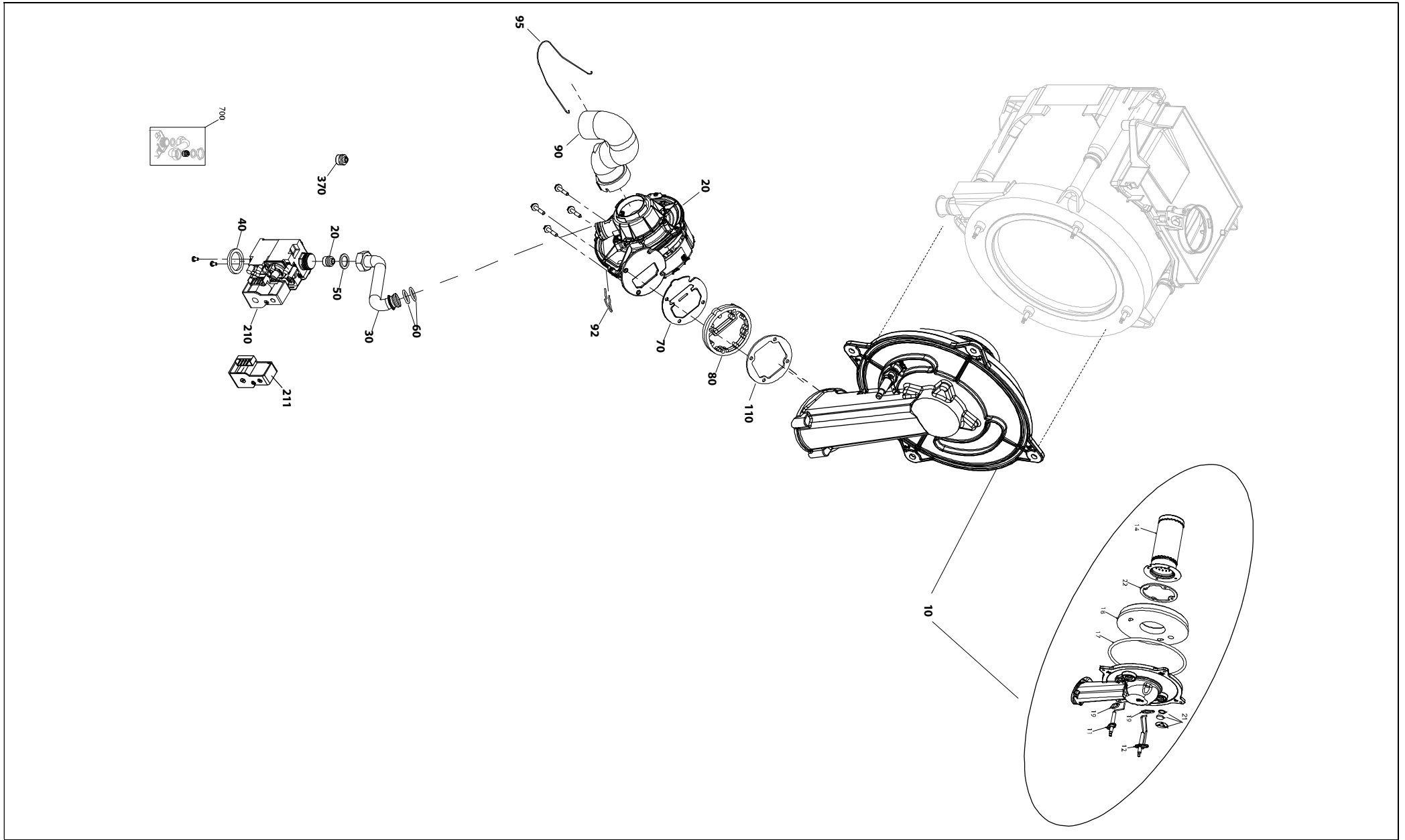



N.	COD.	RC	DESCRIZIONE	DESCRIPTION	DESCRIPTION	BESCHREIBUNG	BESCHRIJVING	DESCRIPCIÓN
10	20198554	20190064	● Convogliatore	Convoyeur d'air	Suction duct	Luftleitblech	Transportinrichting	Transportador
11	20198517		● Elettrodo accensione	Électrode d'allumage	Ignition electrode	Zündelektrode	Ontstekingelektrode	Electrodo de encendido
12	20198520		● Elettrodo rilevazione	Électrode de détection	Flame detection electrode	Prüfelektrode	Meetelektrode	Electrodo de revelación
14	20198559		● Bruciatore	Brûleur	Burner	Brenner	Brander	Quemador
17	20198560		● Isolante	Protection échangeur	Insulating	Isolierung	Isolatie	Aislamiento
18	20198557		● Isolante	Protection échangeur	Insulating	Isolierung	Isolatie	Aislamiento
19	20198521		● Guarnizione	Joint	Seal	Dichtung	Afdichting	Junta
20	20198552		● Ventilatore	Ventilateur	Fan	Gebläse	Ventilator	Ventilador
21	20198515		● Vetrino	Regard	Viewing port	Verschlußstopfen	Glaasje	Cubreobjeto
22	20198558		● Guarnizione bruciatore	Joint brûleur	Burner seal	Brennerdichtung	Brander pakking	Junta quemador
70	4R108411		● Valvola clapet	Clapet	Flap valve	Clapetventil	Stuw	Válvula de retención
80	4R108784		● Distanziale	Entretoise	Spacer	Distanzstück	Compleet tussenstuk verdeler	Distanciador (separador)
90	20187000		● Tubo aspirazione	Tuyau aspiration	Intake	Ansaugrohre	Zuigslang	Tubos de aspiración
92	4365764		● Molletta	Clip	Clip	Feder	Clip	Linguete
95	20187001		● Molletta	Clip	Clip	Feder	Clip	Linguete
110	4R105483		● Guarnizione	Joint	Seal	Dichtung	Afdichting	Junta
210	4R000835		● Valvola gas	Vanne gaz	Gas valve	Gasventil	Gasklep	Válvula de gas
211	4R000824		● Bobina	Bobine	Coil	Spule	Spoel	Bobina
220	20199524		● Ugello MTN	Injecteur methane	Natural gas nozzle	MTN-Düse	MTN Smitmond	Inyector MTN
230	20198550		● Rampa	Tuyau	Pipe	Strecke	Buisje	Rampa
240	4R105534		● Guarnizione flangia	Joint bride	Flange seal	Flanschdichtung	Flensafdichting	Junta brida
250	4363389		● Guarnizione	Joint	Seal	Dichtung	Afdichting	Junta
260	4367112		● Guarnizione	Joint	Seal	Dichtung	Afdichting	Junta
370	4364829		● Diaframma	Diaphragme	Diaphragm	Trennscheibe	Compleet membraan	Diafragma
700	20095285		● Kit trasformazione MTN	Kit transformation méthane	Natural gas conversion lit	Umrüstsatz auf Erdgas	Ombouwset voor methaan	Kit transformación MTN

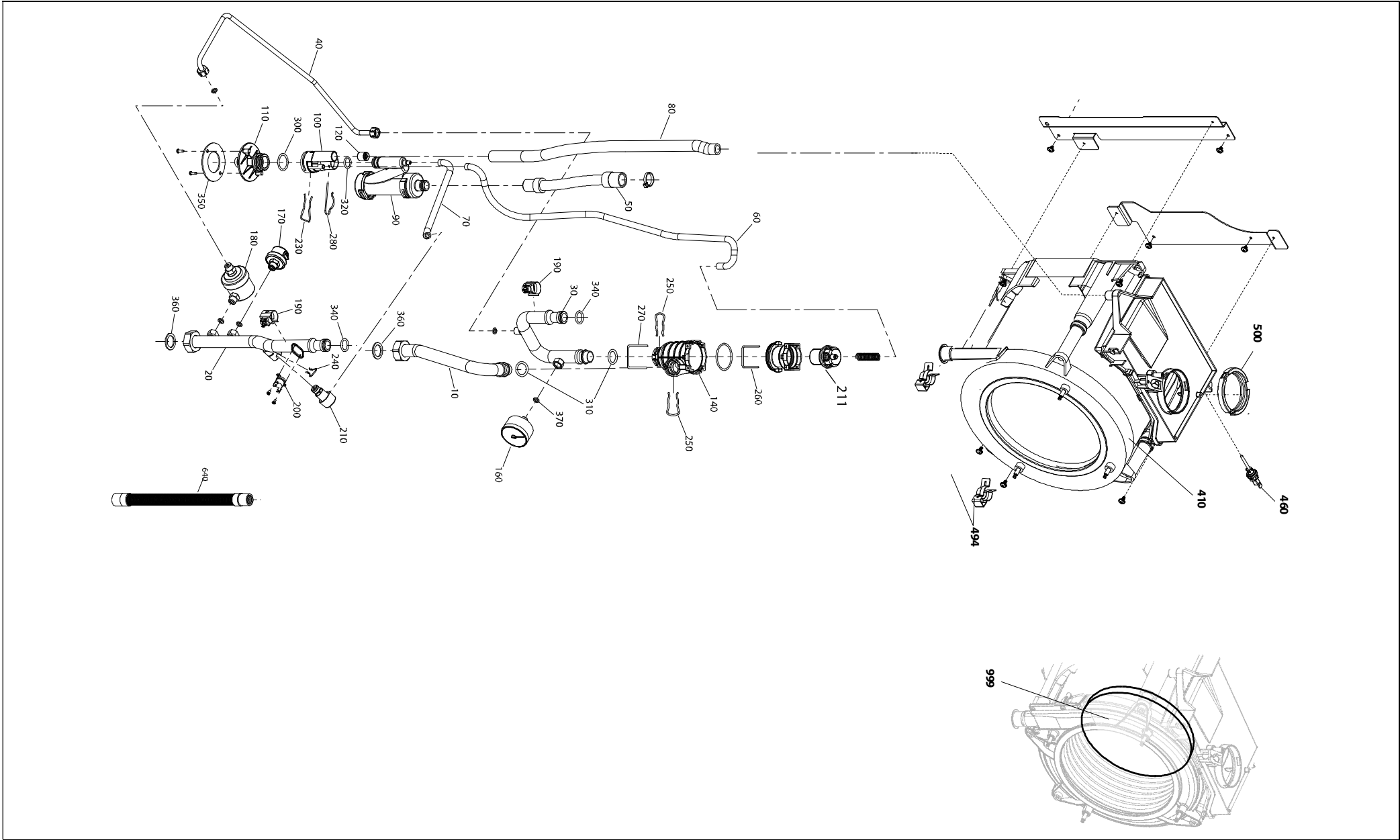

N.	COD.	RC	DESCRIZIONE	DESCRIPTION	DESCRIPTION	BESCHREIBUNG	BESCHRIJVING	DESCRIPCIÓN
10	20198546		● Rampa	Tuyau	Pipe	Strecke	Buisje	Rampa
20	20198547		● Rampa	Tuyau	Pipe	Strecke	Buisje	Rampa
30	20198548		● Rampa	Tuyau	Pipe	Strecke	Buisje	Rampa
40	20198549		● Rampa	Tuyau	Pipe	Strecke	Buisje	Rampa
50	20198551		● Tubo condensa	Tuyau buée	Condensation pipe	Kondensatbogen	Condensatie slang	Tubo condensación
60	4R102585		● Tubetto silicone	Tube en silicone	Silicon tube	Silikonröhrchen	Silicone slang	Tubo de silicona
70	4R109990		● Tubetto silicone	Tube en silicone	Silicon tube	Silikonröhrchen	Silicone slang	Tubo de silicona
80	20202277		● Tubo scarico condensa	Tuyau évacuation buée	Condensation drainage pipe	Abflussrohr Kondenswasser	Condensafvoerslang	Tubo evacuación de condensados
90	4R109674		● Sifone	Siphon	Syphon	Syphon	Sifon	Sifón
100	4R109666		● Collettore scarico condensa	Collecteur évacuation condensation	Condensation drainage manifold	Auspuffsammler	Colector de drenagem	Colector evacuación de condensados
110	20195198		● Supporto	Support	Support	Halter	Selhouder	Cierre
120	4R109675		● Valvola di non ritorno	Vanne anti-retour	Non-return valve	Rückschlagventil	Terugslagklep	Válvula de retención
140	4R001159		● Corpo degasatore	Corps dégazer	Gas extractor body	Entgaserkörper	Ontgasser behuizing	Cuerpo desaireador (purgador)
160	4R105331		● Manometro	Manometre	Pressure gauge	Manometer	Manometer	Manómetro
170	20198544		● Trasduttore di pressione	Transducteur de pression	Pressure transducer	Druckgebersatz	Druktransductor	Kit trasductor presión
180	4R002098		● Pressostato differenziale	Pressostat différentiel	Differential pressure switch	Differenzdruckwächter	Differentiaal drukregelaar	Presostato diferencial
190	20198561		● Sonda temperatura	Sonde température	Temperature probe	Temperaturfühler	Temperatuur sensor	Sensor temperatura
200	4364948	C	● Termostato limite	Thermostat limite	Maximum temperature thermostat	Grenzthermostat	Klicson	Termostato límite
210	4366392		● Rubinetto scarico	Robinet de vidange	Drain cock	Ablasshahn	Afvoerkraan	Llave de vaciado
211	4365707		● Disaereatore	Purgeur automatique	Deaerator	Entlüfter	Ontluchter	Purgador
230	4365407		● Molletta	Clip	Clip	Feder	Clip	Linguete
240	4366394		● Molletta	Clip	Clip	Feder	Clip	Linguete
250	4365623		● Molletta	Clip	Clip	Feder	Clip	Linguete
260	4366963		● Molletta	Clip	Clip	Feder	Clip	Linguete

N.	COD.	RC 20190064	DESCRIZIONE	DESCRIPTION	DESCRIPTION	BESCHREIBUNG	BESCHRIJVING	DESCRIPCIÓN
280	4364962	•	Molletta	Clip	Clip	Feder	Clip	Linguete
300	4365860	•	Anello di tenuta	Joint d'etancheite	O-ring	OR-Dichtung	Pakkingring	Anillo de cierre
310	4364282	•	Anello di tenuta	Joint d'etancheite	O-ring	OR-Dichtung	Pakkingring	Anillo de cierre
320	4R105704	•	Anello OR	Joint d'etancheite	O-ring	OR-Dichtung	Pakkingring	Anillo de cierre
340	4R106930	•	Anello OR	Joint d'etancheite	O-ring	OR-Dichtung	Pakkingring	Anillo de cierre
350	4R109676	•	Guarnizione	Joint	Seal	Dichtung	Afdichting	Junta
360	4363781	•	Guarnizione	Joint	Seal	Dichtung	Afdichting	Junta
370	4363799	•	Guarnizione	Joint	Seal	Dichtung	Afdichting	Junta
410	20198553	•	Scambiatore condensante	Echangeur condensant	Heat exchanger	Kondensaustauscher	Condensatie wisselaar	Intercambiador condensador
460	4R105463	•	Sonda fumi	Sonde fumée	Flue gas probe	Abgasfühler	Rook sensor	Sonda de humos
494	4366958	•	Molletta	Clip	Clip	Feder	Clip	Linguete
500	4366238	•	Guarnizione	Joint	Seal	Dichtung	Afdichting	Junta
640	4R102771	•	Tubo scarico condensa	Tuyau évacuation buée	Condensation drainage pipe	Abflussrohr Kondenswasser	Condensafvoerslang	Tubo evacuación de condensados
999	4R107776	•	Pannello isolamento	Panneau isolation	Insulation panel	Isoliertafel	Paneelvulling	Panel aislante

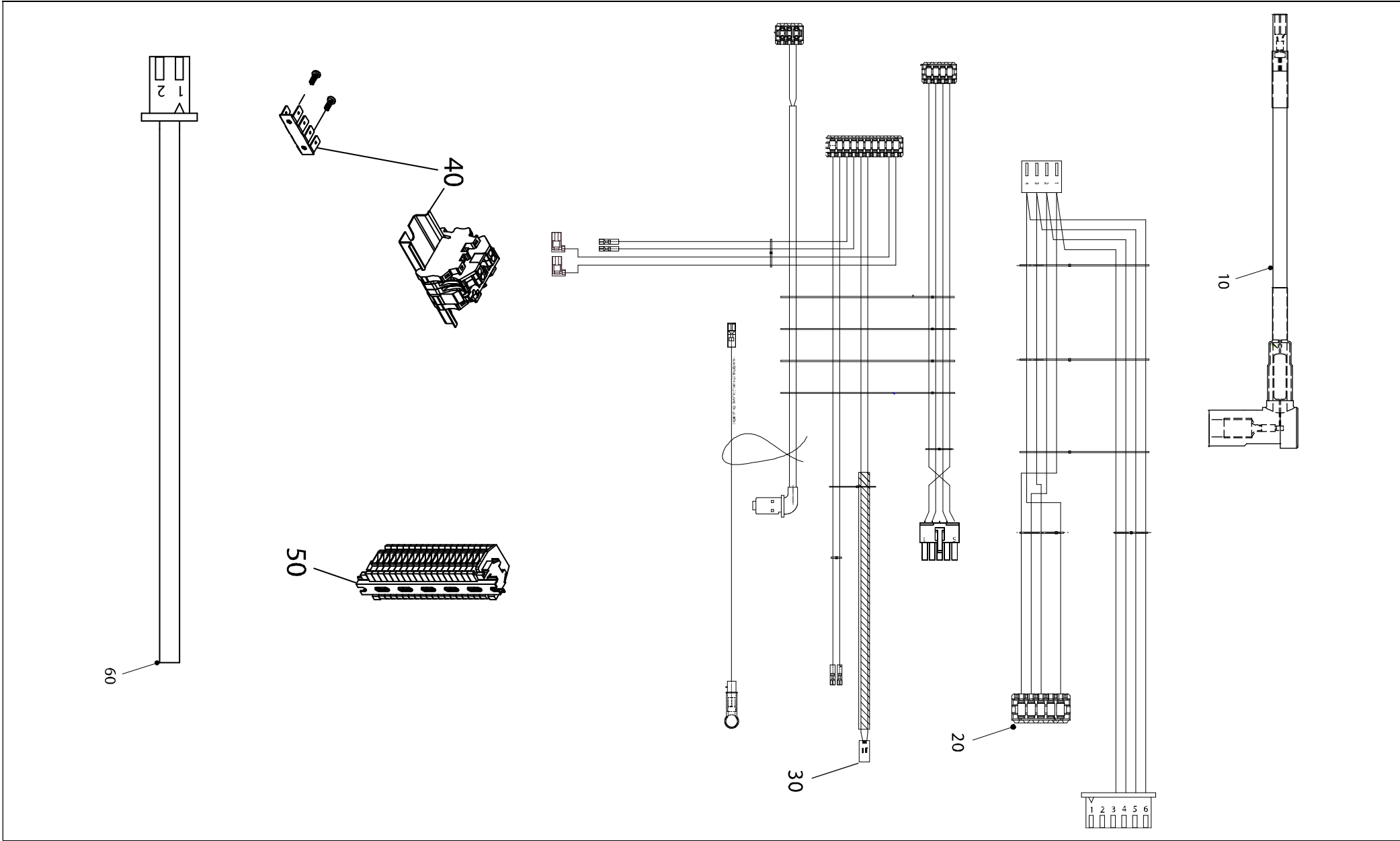

N.	COD.	RC	DESCRIZIONE	DESCRIPTION	DESCRIPTION	BESCHREIBUNG	BESCHRIJVING	DESCRIPCIÓN
10	4R109814	20190064	• Cablaggio candela	Câblage bougie	Spark wiring	Kerze Verkabelung	Bekabeling bougie	Cableado electrodo
20	20198562		• Cablaggio	Câblage	Wiring	Verkabelung	Bekabeling	Cableado
30	20198563		• Cablaggio bassa tensione	Câblage à basse tension	Low tension wiring	Verkabelung Niederspannung	Bekabeling laagspanning	Cableado baja tensión
40	20198564		• Cablaggio alimentazione	Câblage alimentation	Feed wiring	Speiseverkabelung	Bekabeling voeding	cableado alimentación
50	20198565		• Cablaggio	Câblage	Wiring	Verkabelung	Bekabeling	Cableado
60	4R109867		• Cablaggio termostato	Cablage thermostat	Thermostat wiring	Thermostat Verkabelung	Bekabeling thermostaat	Cableado termostato

A = Ricambi per dotazione minima - Pièces détachées pour équipement minimum - Spare parts for minimum fittings - Ersatzteile für minimale Ausstattung - Reserveonderdelen voor minimale uitrusting - Recambios para equipamiento mínimo

A+B = Ricambi per dotazione base di sicurezza - Pièces détachées pour équipement standard de sécurité - Spare parts for basic safety fittings - Ersatzteile für sicherheitsgrundausrüstung - Reserveonderdelen voor basis veiligheidsuitrusting - Recambios para equipamiento básico de seguridad

A+B+C = Ricambi per dotazione estesa di sicurezza - Pièces détachées pour équipement complet de sécurité - Spare parts for extended safety fittings - Ersatzteile für erweiterte Sicherheitsgrundausrüstung - Reserveonderdelen voor uitgebreide veiligheidsuitrusting - Recambios para equipamiento general de seguridad

---



**Riello S.p.A.**  
37045 Z.A.I. di San Pietro di Legnago (Verona) Via Ing. Pilade Riello, 7  
Tel. 0442/630.111 - Fax 0442/22378 <http://www.riello.it>  
archivio <http://ics.riello.it>

---

La nostra azienda, nella costante azione migliorativa sul prodotto, si riserva la possibilità di modificare i dati riportati in questo documento in qualsiasi momento e senza preavviso. - Puisque l'entreprise cherche constamment à perfectionner toute sa production, les caractéristiques esthétiques et dimensionnelles, les données techniques, les équipements et les accessoires, peuvent subir des modifications. - The manufacturer strives to continuously improve all products. Appearance, dimensions, technical specifications, standard equipment and accessories are therefore liable to modification without notice. - Da das Unternehmen konstant um die Perfektionierung seiner Produktion bemüht ist, können das äußere Erscheinungsbild, die Abmessungen, die technischen Daten, die Ausstattungen sowie Zubehörteile Änderungen unterworfen werden. - In een voortdurend streven naar het verbeteren van onze producten, behouden wij ons het recht voor om de gegevens in dit document op elk moment te wijzigen, zonder kennisgeving vooraf. - Nuestra empresa dedica sus esfuerzos al constante perfeccionamiento de toda su producción; por eso las características estéticas y las dimensiones, los datos técnicos, los equipamientos y los accesorios pueden estar sometidos a variación. 7272